

# Phase noise

MMIC Design and Technology

*Ali Medi*

# Outline

- Introduction
- Phase Noise
- Output Phase Noise Spectrum
- On chip Inductors
- Advanced On Chip Inductor

# Outline

- Introduction
- Phase Noise
- Output Phase Noise Spectrum
- On chip Inductors
- Advanced On Chip Inductor

# Introduction

- Virtually every component in the system can seriously degrade the phase noise (**intrinsic noise**).
- In addition, phase noise can result from undesired and often unexpected interaction between components.
- Most MMIC manufacturers do not supply phase noise data and experimentation is usually required.

# Outline

- Introduction
- Phase Noise
- Output Phase Noise Spectrum
- On chip Inductors
- Advanced On Chip Inductor

# Phase Noise in Wireless Systems

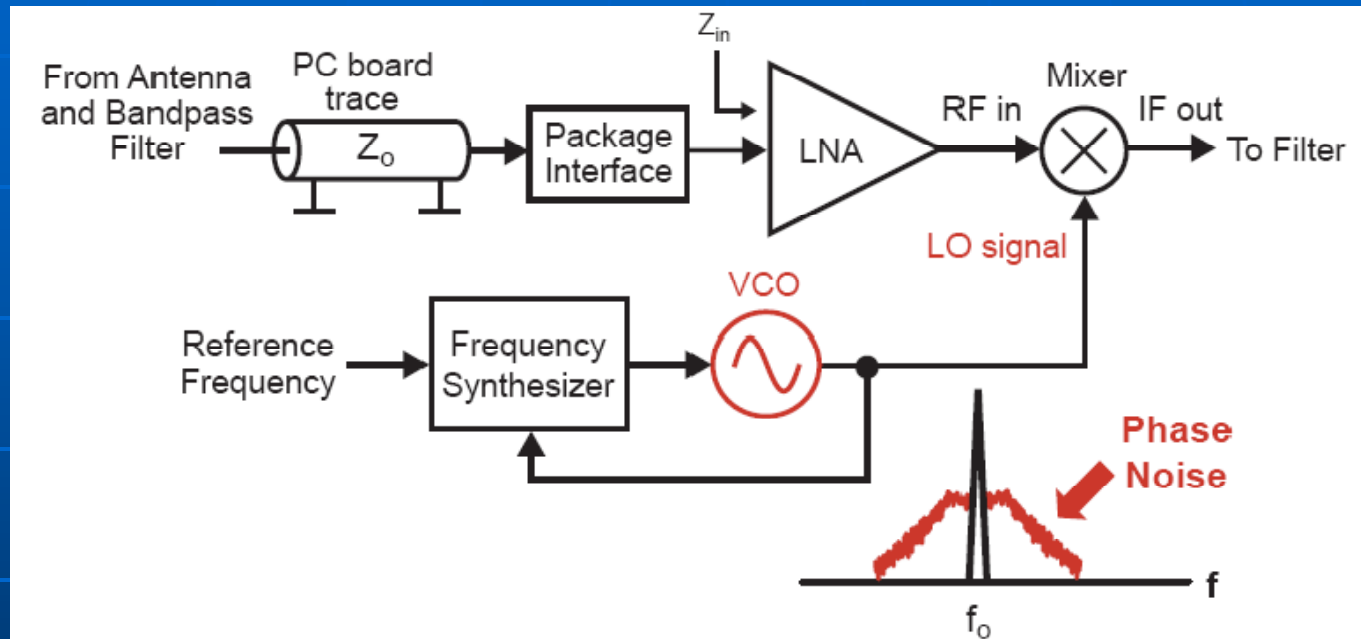

- VCO noise has a negative impact on system performance
  - Receiver: lower sensitivity, poorer blocking performance
- Noise is characterized in frequency domain

# Phase noise

$$L(\Delta\omega) = 10\log\left(\frac{\text{Noise power in a 1Hz bandwidth at a frequency } \omega_0 + \Delta\omega}{\text{Carrier power}}\right)$$

*[dBc/Hz]*

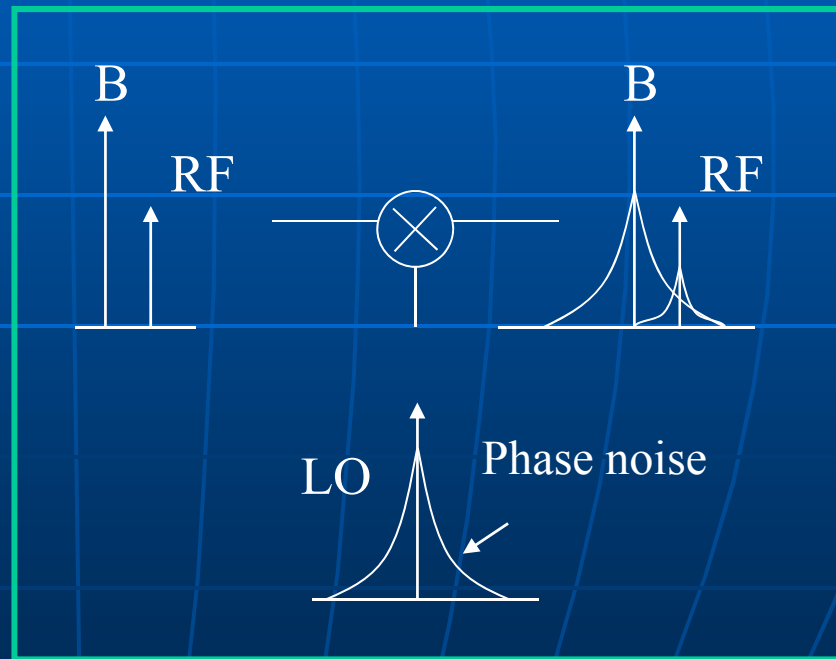
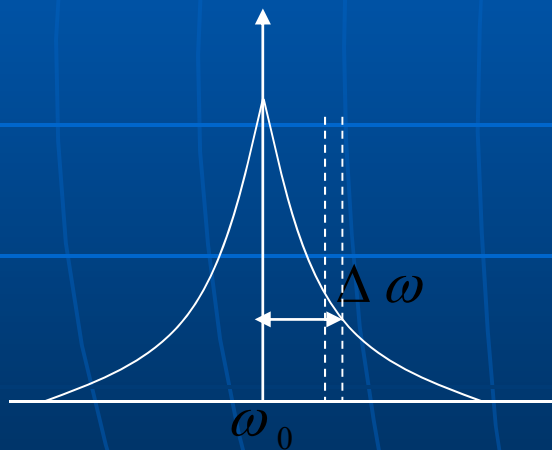

# Phase noise

Noise Power density increase due to blocking signal:

$$P_{n,b} = P_b L\{f_{LO} - f_b\} = P_b L\{\Delta f\}$$

$$C/I = S_{\text{désiré}} [dBm] - (S_{bl}(\Delta f_c) [dBm] \cdot L(\Delta f_c) + 10 \log B)$$

$$L(\Delta f_c) [dBc/Hz] < S_{\text{désiré}} [dBm] - S_{bl}(\Delta f_c) [dBm] - C/I_{\min} [dB] - 10 \log B$$

Blocking signals at:

$$\bullet 250\text{kHz} \Rightarrow L_1(250\text{kHz}) < -72\text{dBc/Hz} \Rightarrow L_1(500\text{kHz}) = -72\text{dBc/Hz} + 20 \log \frac{250}{500} < -78\text{dBc/Hz}$$

$$\bullet 500\text{kHz} \Rightarrow L_2(500\text{kHz}) < -93\text{dBc/Hz}$$



# Frequency-Reference Noise (Phase Noise)

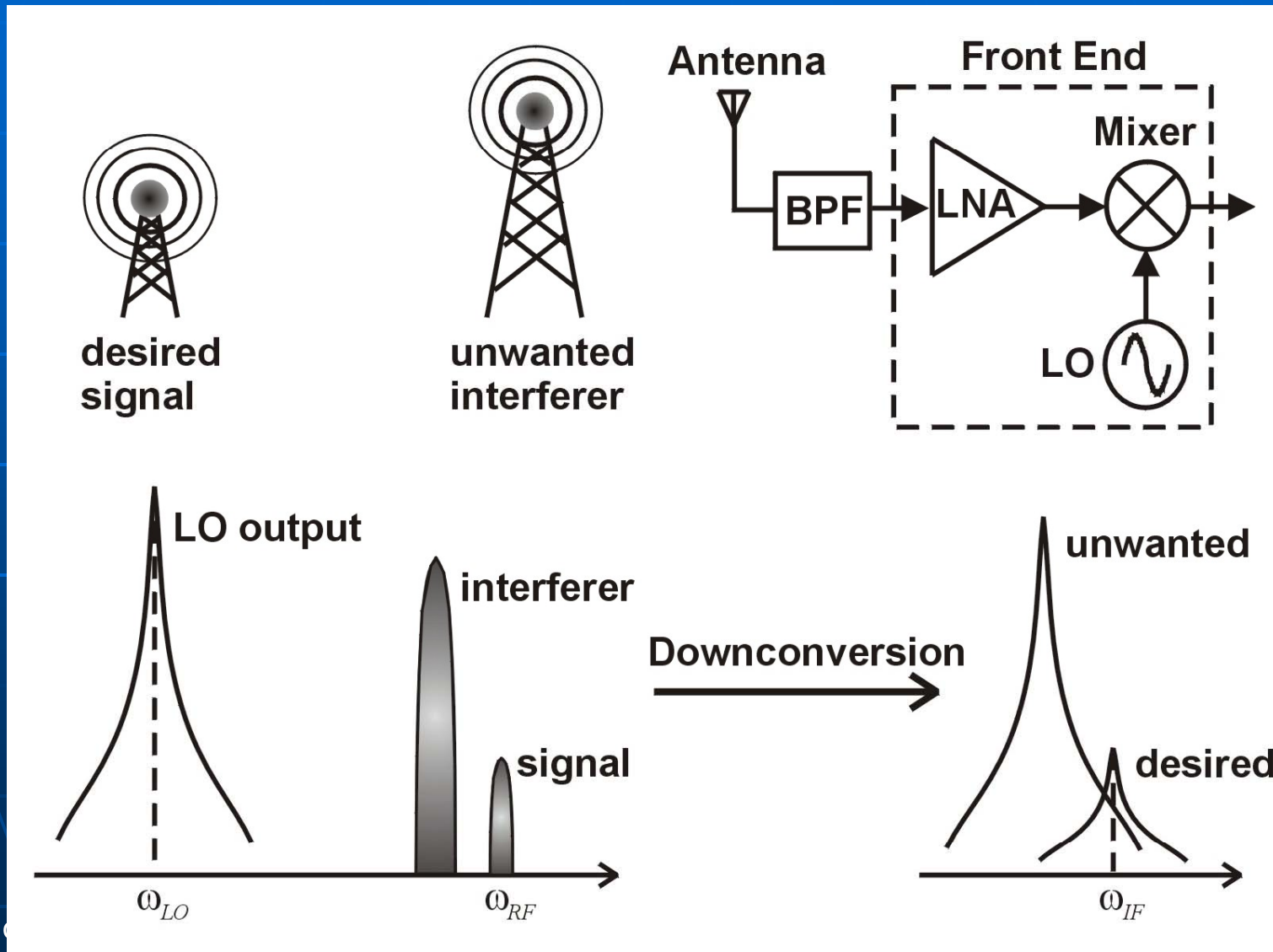

# Oscillator Phase Noise

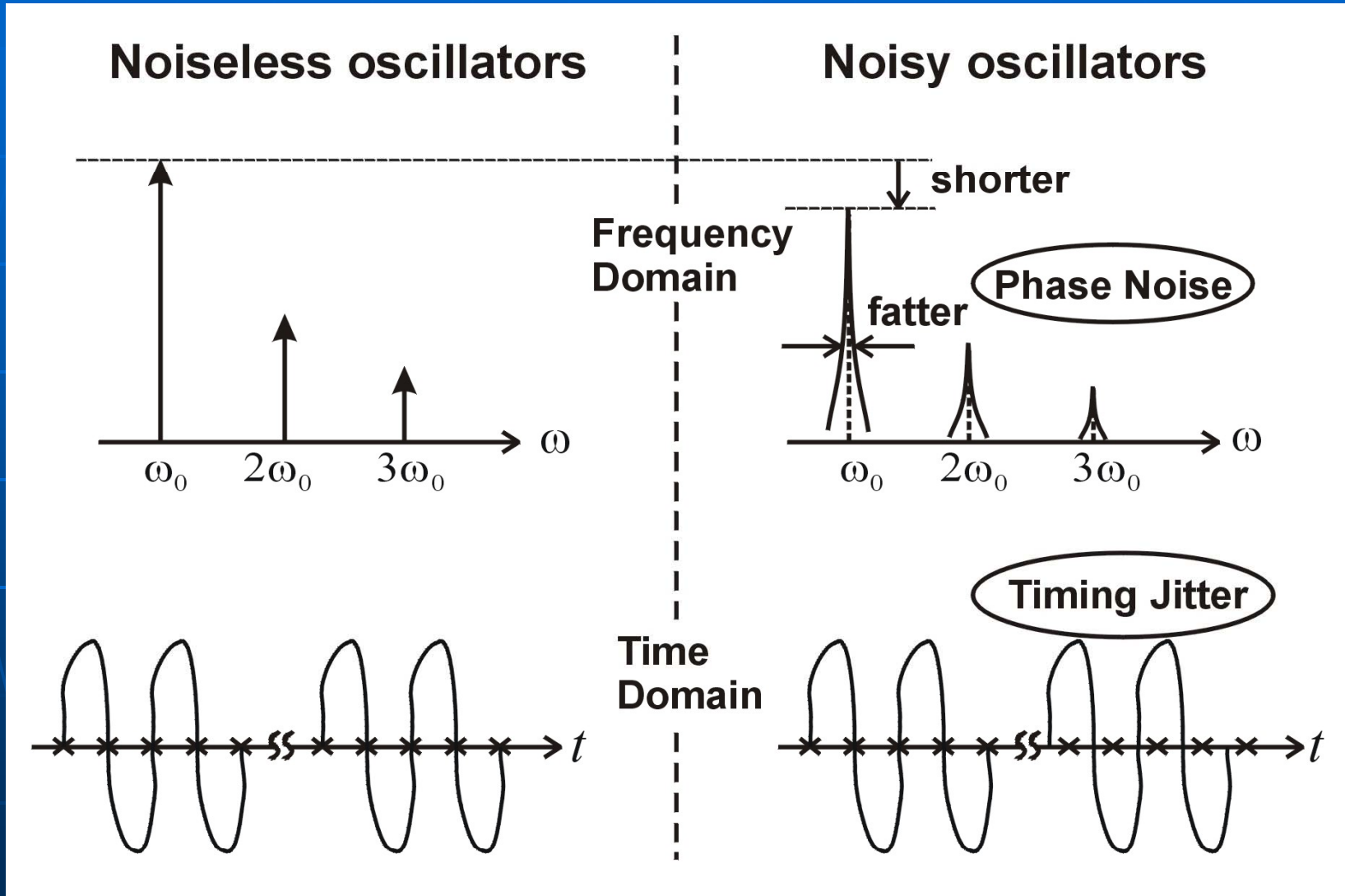

# Noise Sources Impacting Phase Noise

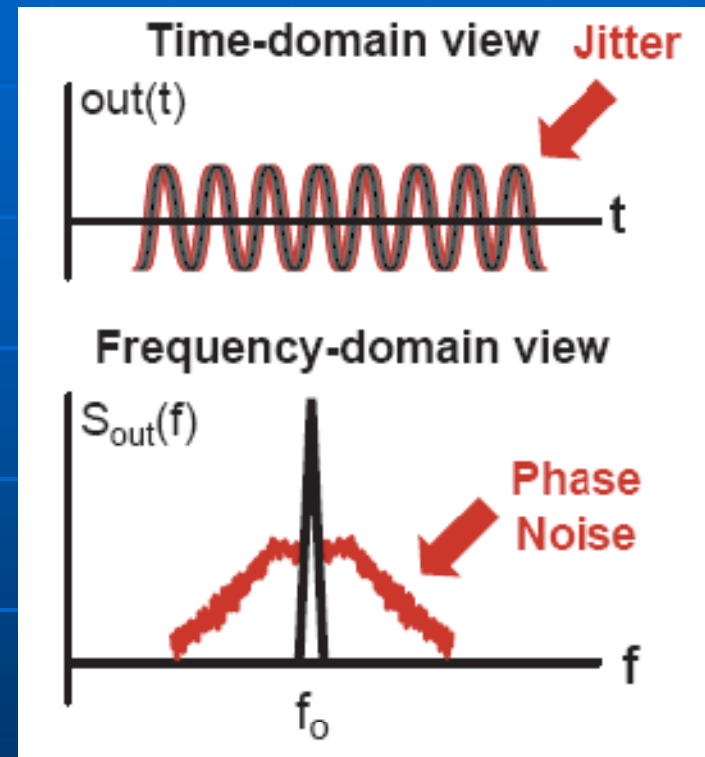
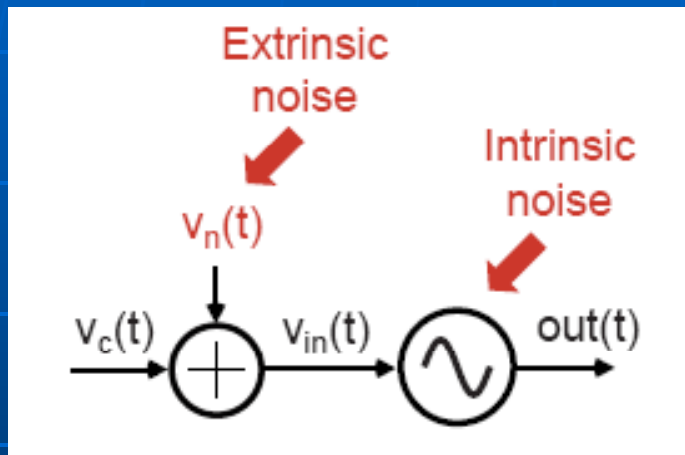

- Extrinsic noise - Noise from other circuits (including PLL)
- Intrinsic noise - Noise due to the VCO circuitry

# Measurement of Phase Noise in dBc/Hz

- Definition of  $L(f)$

$$L(f) = 10 \log \left( \frac{\text{Spectral density of noise}}{\text{Power of carrier}} \right)$$

- Units are dBc/Hz

$$L(\Delta f) = 10 \log \left( \frac{S_{noise}(\Delta f)}{P_{sig}} \right)$$

# Outline

- Introduction
- Phase Noise
- Output Phase Noise Spectrum
- On chip Inductors
- Advanced On Chip Inductor

# Output Phase Noise Spectrum

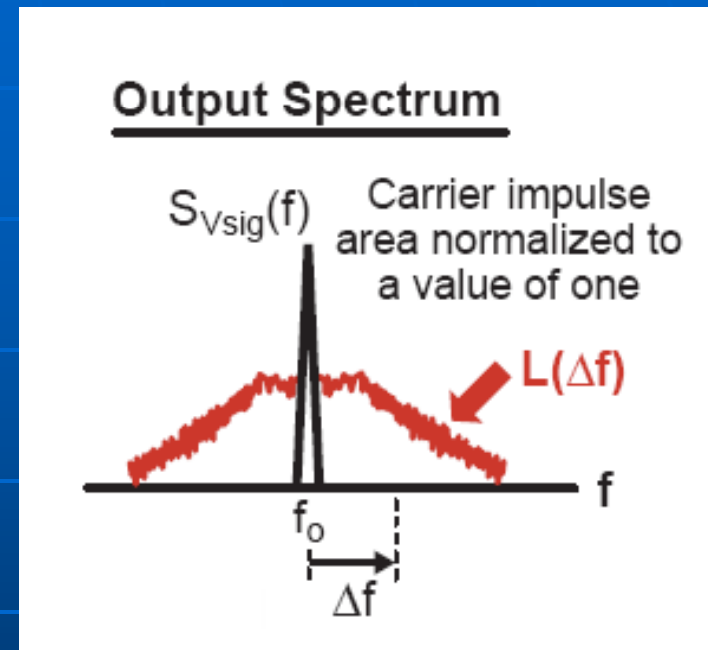
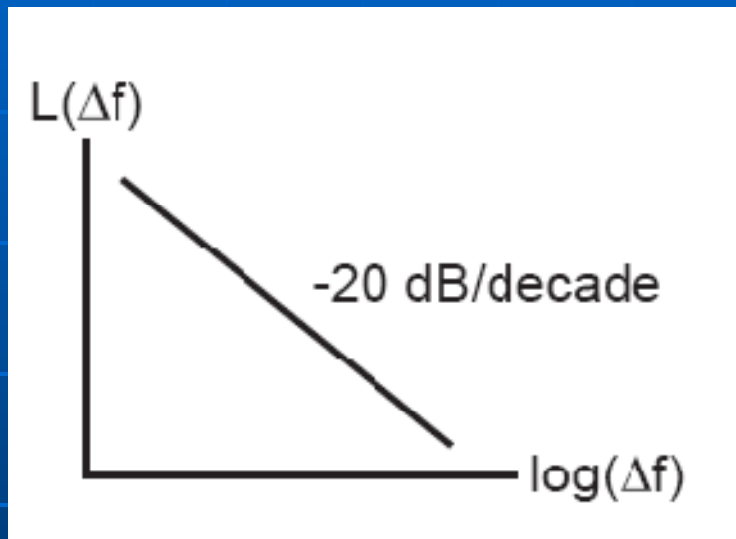

$$L(\Delta f) = 10 \log \left( \frac{4kT}{P_{sig}} \left( \frac{1}{2Q} \frac{f_o}{\Delta f} \right)^2 \right)$$

# Oscillator Phase Noise

Effect of power consumption and inductor quality on oscillator ■

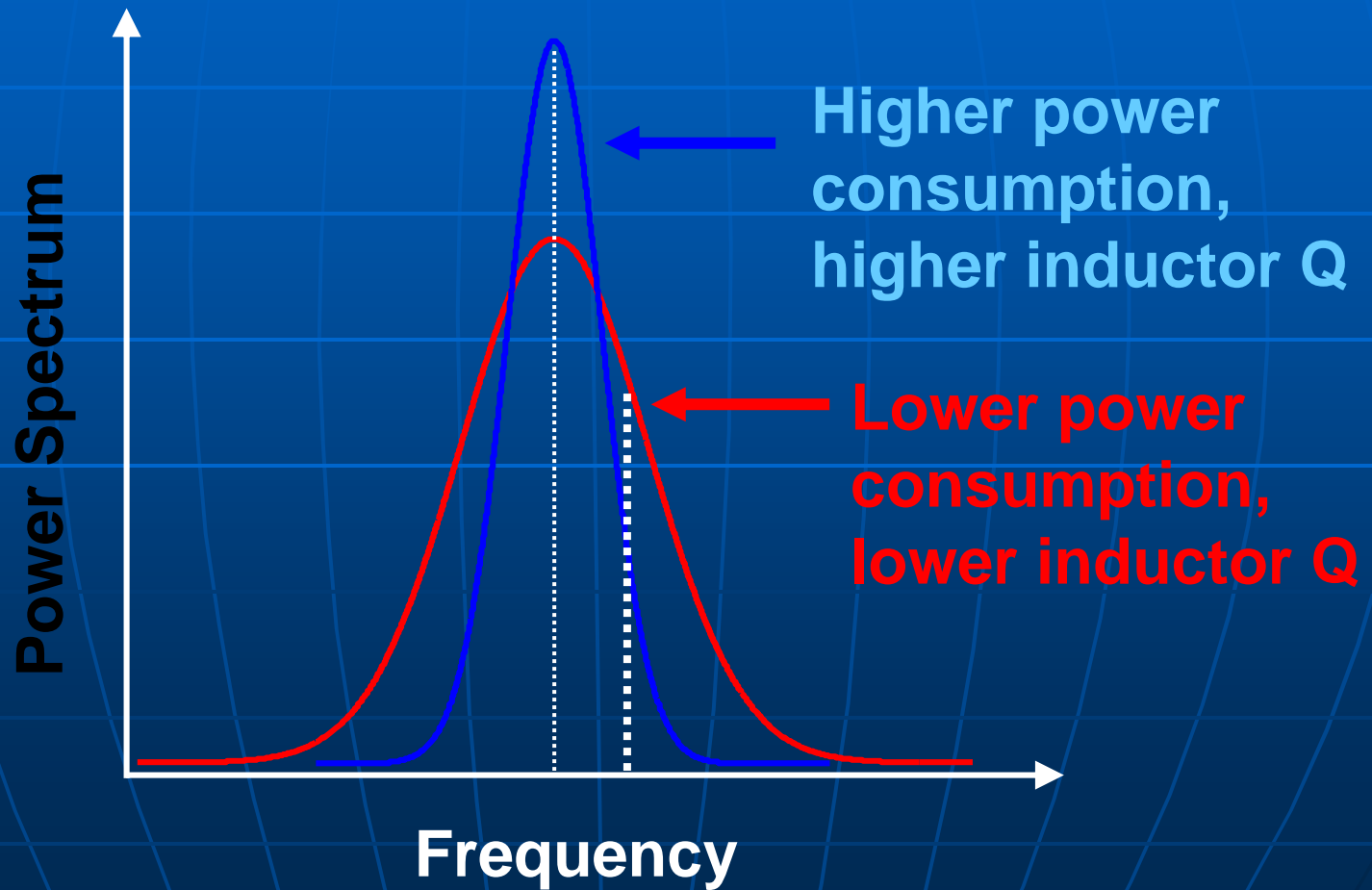

# Phase Noise of A Practical Oscillator

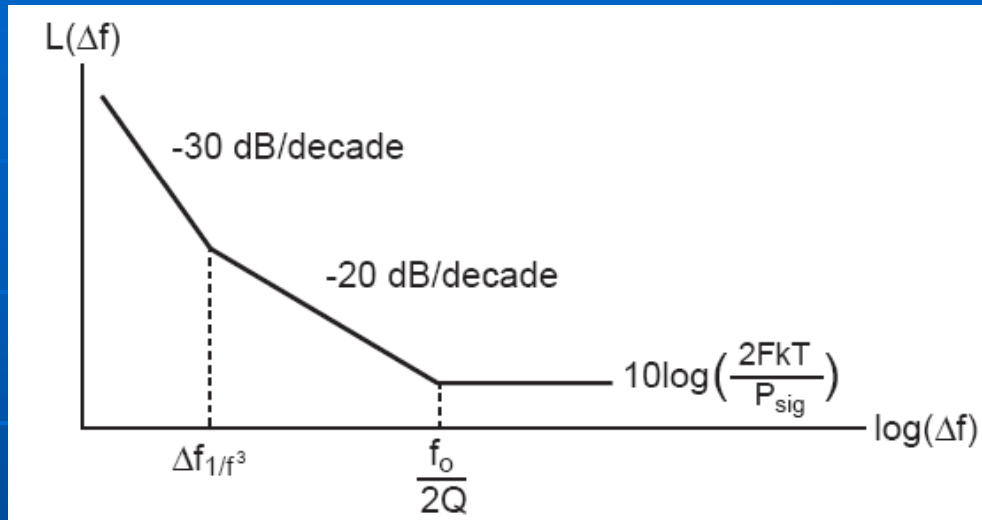

- Phase noise drops at  $-20$  dB/decade over a wide frequency range, but deviates from this at:
  - Low frequencies – slope increases (often  $-30$  dB/decade)
  - High frequencies – slope flattens out (oscillator tank does not filter all noise sources)
- Frequency breakpoints and magnitude scaling are not readily predicted by the analysis approach taken so far.



# Phase Noise of A Practical Oscillator

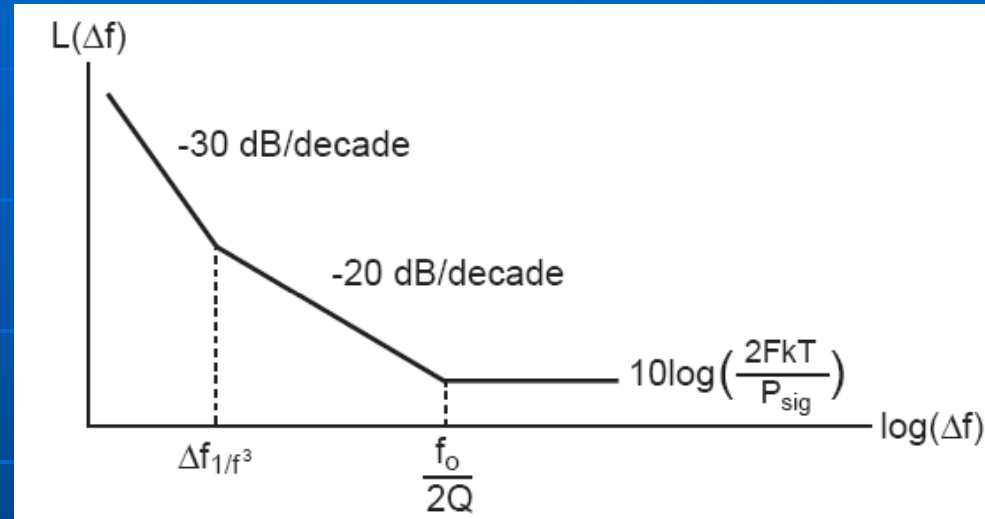

- Leeson proposed modification of the phase noise expression to capture the above noise profile

$$L(\Delta f) = 10 \log \left( \frac{2FkT}{P_{sig}} \left( 1 + \left( \frac{1}{2Q} \frac{f_o}{\Delta f} \right)^2 \right) \left( 1 + \frac{\Delta f_{1/f^3}}{|\Delta f|} \right) \right)$$

- Note: he assumed that  $F(\Delta f)$  was constant over frequency

# Calculation of Intrinsic Phase Noise in Oscillators

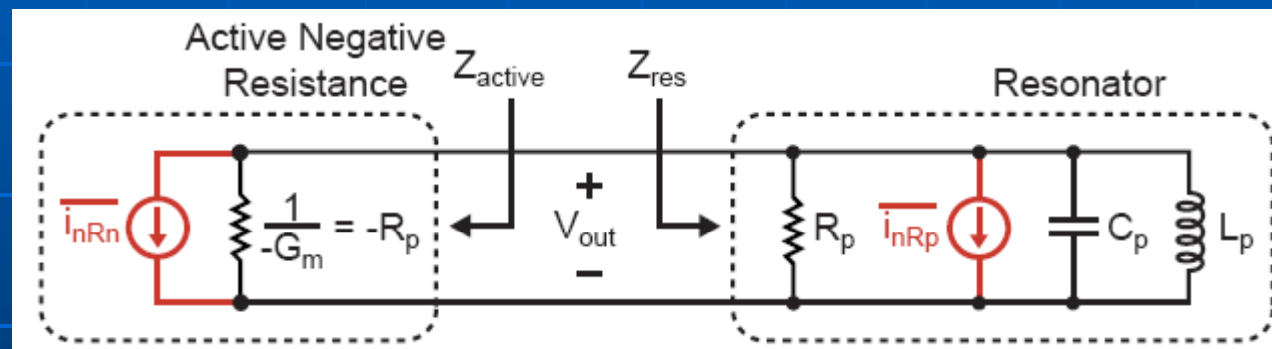
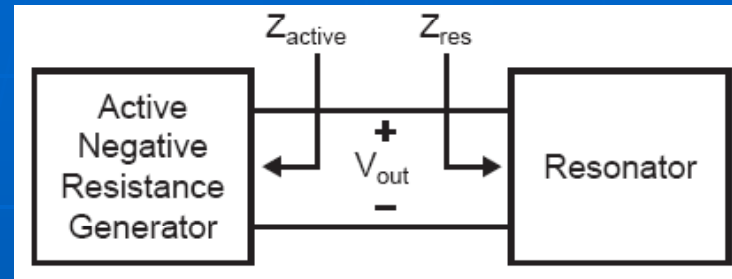

- Noise sources in oscillators are put in two categories
- Noise due to tank loss
- Noise due to active negative resistance
- We want to determine how these noise sources influence the phase noise of the oscillator

# Equivalent Model for Noise Calculations

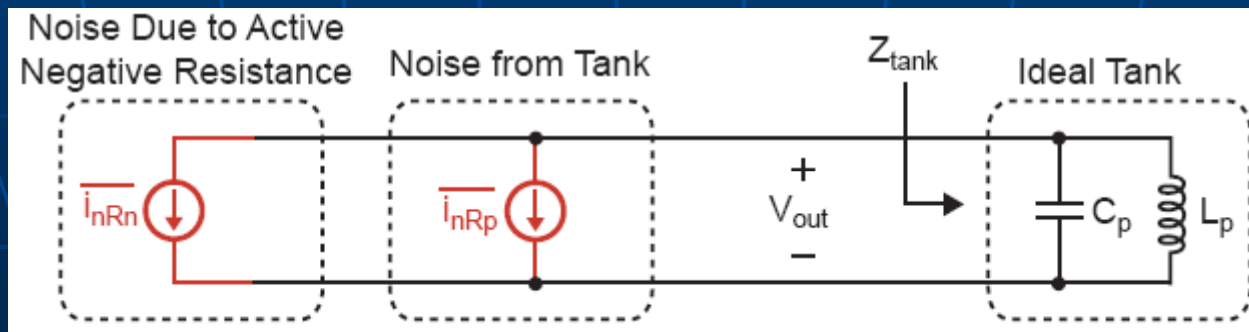
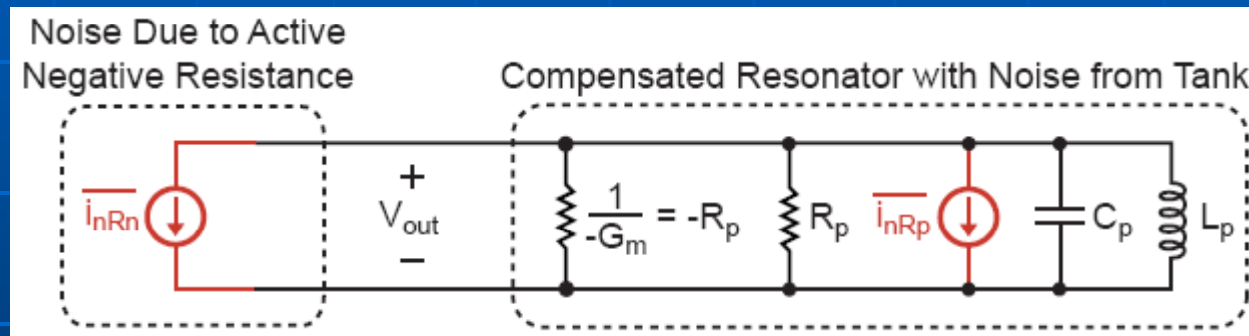
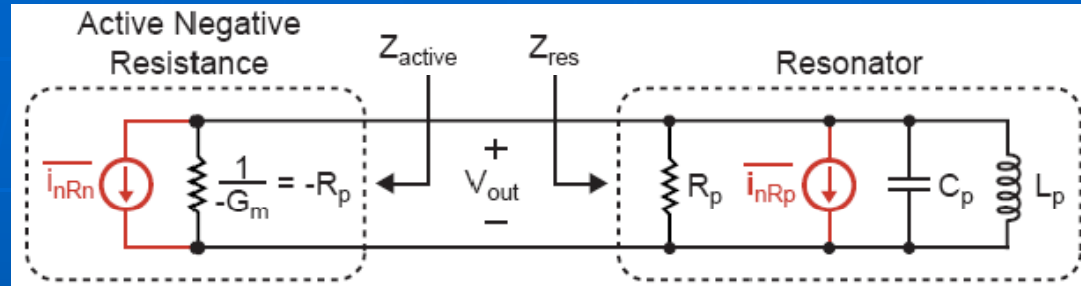

# Calculate Impedance Across Ideal LC Tank Circuit

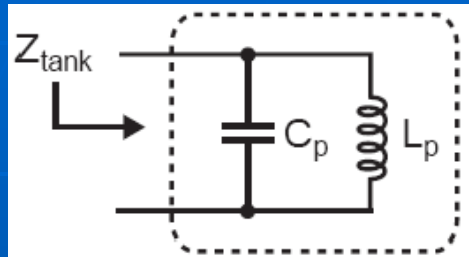

$$Z_{tank}(w) = \frac{1}{jwC_p} \parallel jwL_p = \frac{jwL_p}{1 - w^2L_pC_p}$$

## ■ Calculate input impedance about resonance

- Consider:

$$w = w_o + \Delta w, \text{ where } w_o = \frac{1}{\sqrt{L_pC_p}}$$

$$Z_{tank}(\Delta w) = \frac{j(w_o + \Delta w)L_p}{1 - (w_o + \Delta w)^2L_pC_p}$$

$$= \frac{j(w_o + \Delta w)L_p}{\underbrace{1 - w_o^2L_pC_p}_{=0} - 2\Delta w(w_oL_pC_p) - \underbrace{\Delta w^2L_pC_p}_{\text{negligible}}} \approx \frac{j(w_o + \Delta w)L_p}{-2\Delta w(w_oL_pC_p)}$$



$$Z_{tank}(\Delta w) \approx \frac{jw_oL_p}{-2\Delta w(w_oL_pC_p)} = \boxed{-\frac{j}{2} \frac{1}{w_oC_p} \left( \frac{w_o}{\Delta w} \right)}$$

# A Convenient Parameterization of LC Tank Impedance

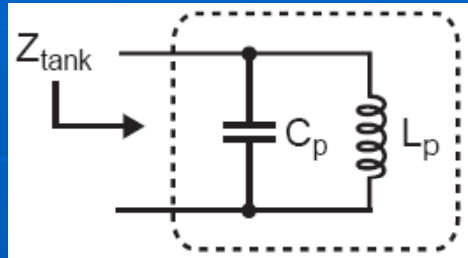

$$Z_{tank}(\Delta\omega) \approx -\frac{j}{2\omega_o C_p} \left( \frac{\omega_o}{\Delta\omega} \right)$$

- Actual tank has loss that is modeled with  $R_p$ 
  - Define  $Q$  according to actual tank

$$Q = R_p \omega_o C_p \Rightarrow \frac{1}{\omega_o C_p} = \frac{R_p}{Q}$$

- Parameterize ideal tank impedance in terms of  $Q$  of actual tank

$$Z_{tank}(\Delta\omega) \approx -\frac{j R_p}{2 Q} \left( \frac{\omega_o}{\Delta\omega} \right)$$



$$|Z_{tank}(\Delta f)|^2 \approx \left( \frac{R_p f_o}{2Q \Delta f} \right)^2$$

# Overall Noise Output Spectral Density

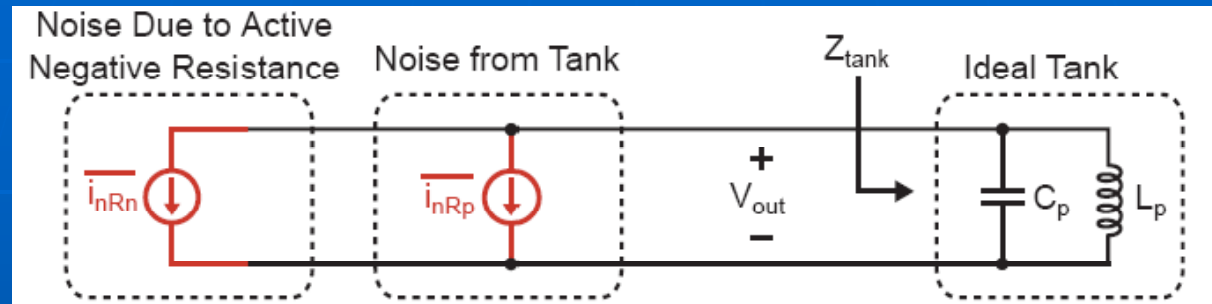

- Assume noise from active negative resistance element and tank are uncorrelated

$$\begin{aligned}\frac{\overline{v_{out}^2}}{\Delta f} &= \left( \frac{\overline{i_{nRp}^2}}{\Delta f} + \frac{\overline{i_{nRn}^2}}{\Delta f} \right) |Z_{tank}(\Delta f)|^2 \\ &= \frac{\overline{i_{nRp}^2}}{\Delta f} \left( 1 + \frac{\overline{i_{nRn}^2}}{\Delta f} / \frac{\overline{i_{nRp}^2}}{\Delta f} \right) |Z_{tank}(\Delta f)|^2\end{aligned}$$

- Note that the above expression represents total noise that impacts both amplitude and phase of oscillator output

# Parameterize Noise Output Spectral Density

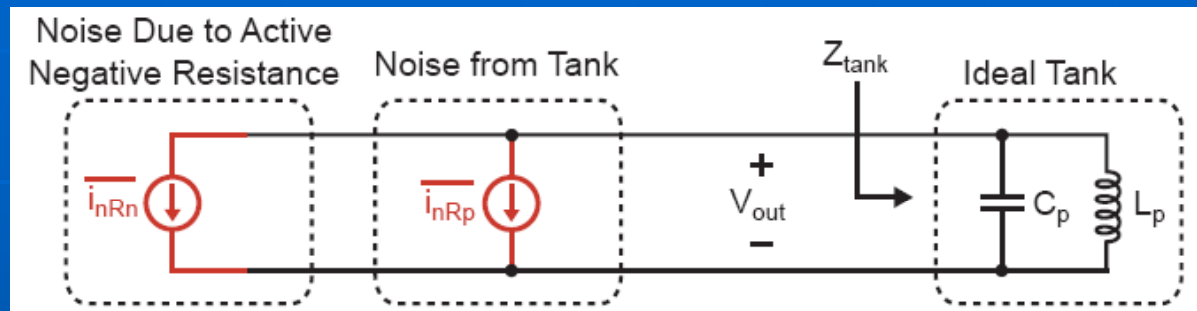

- From previous slide

$$\frac{\overline{v_{out}^2}}{\Delta f} = \frac{\overline{i_{nRp}^2}}{\Delta f} \underbrace{\left( 1 + \frac{\overline{i_{nRn}^2}}{\Delta f} / \frac{\overline{i_{nRp}^2}}{\Delta f} \right)}_{F(\Delta f)} |Z_{tank}(\Delta f)|^2$$

- $F(\Delta f)$  is defined as

$$F(\Delta f) = \frac{\text{total noise in tank at frequency } \Delta f}{\text{noise in tank due to tank loss at frequency } \Delta f}$$

# Fill in Expressions

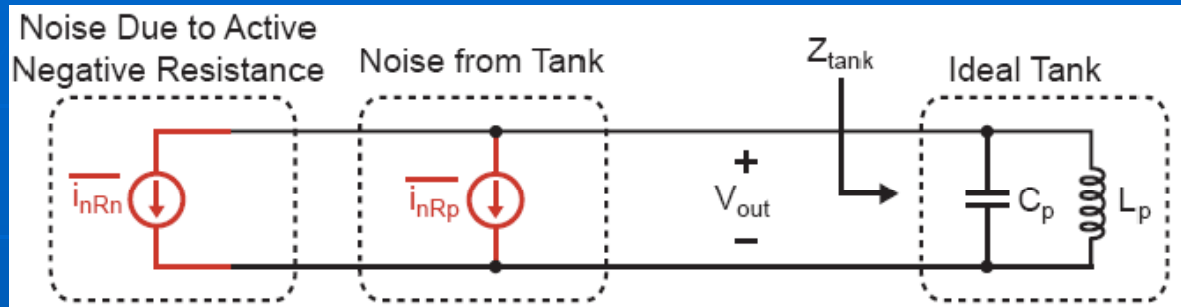

- Noise from tank is due to resistor  $R_p$

$$\overline{i_{nRp}^2} = 4kT \frac{1}{R_p} \Delta f$$

- $Z_{tank}(\Delta f)$  found previously

$$|Z_{tank}(\Delta f)|^2 \approx \left( \frac{R_p f_o}{2Q \Delta f} \right)^2$$

- Output noise spectral density expression (single-

$$\overline{v_{out}^2} = 4kT \frac{1}{R_p} F(\Delta f) \left( \frac{R_p f_o}{2Q \Delta f} \right)^2 = 4kT F(\Delta f) R_p \left( \frac{1 f_o}{2Q \Delta f} \right)^2$$



# Separation into Amplitude and Phase Noise

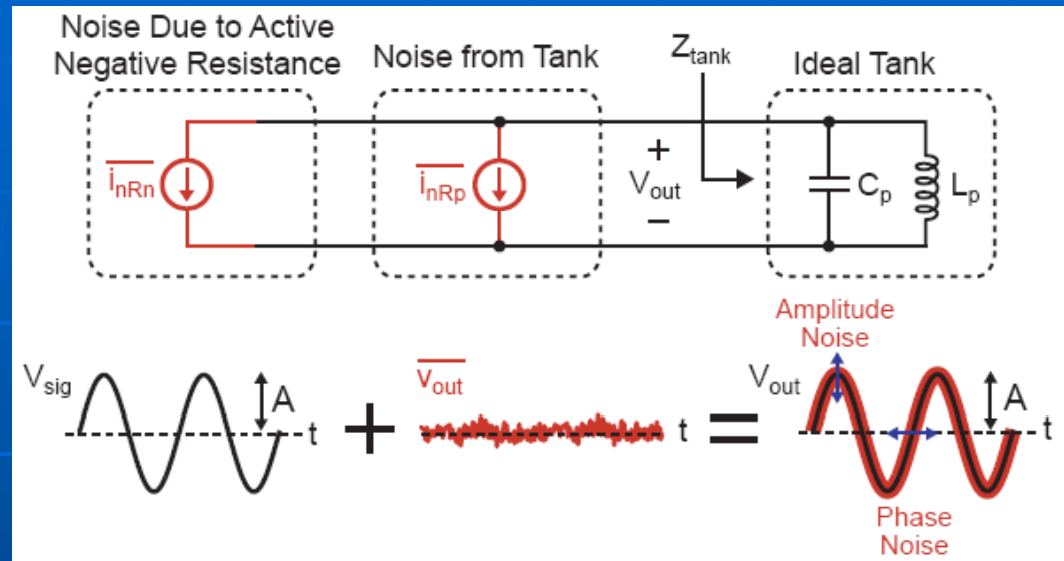

- Noise impact splits evenly between amplitude and phase
  - Amplitude variations suppressed by feedback in oscillator

$$\frac{\overline{v_{out}^2}}{\Delta f} \Big|_{\text{phase}} = 2kTF(\Delta f)R_p \left( \frac{1}{2Q} \frac{f_o}{\Delta f} \right)^2$$

# Output Phase Noise Spectrum (Leeson's Formula)

$$L(\Delta f) = 10 \log \left( \frac{\text{Spectral density of noise}}{\text{Power of carrier}} \right)$$

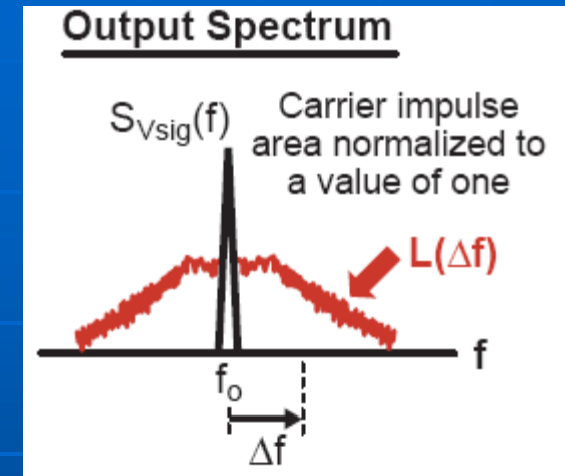
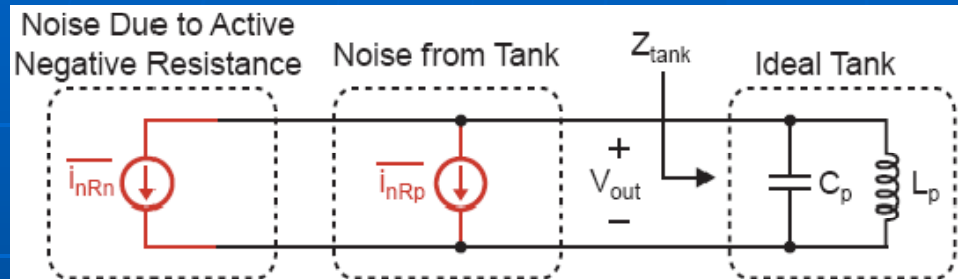

- All power calculations are referenced to the tank loss resistance,  $R_p$

$$P_{sig} = \frac{V_{sig,rms}^2}{R_p} = \frac{(A/\sqrt{2})^2}{R_p}, \quad S_{noise}(\Delta f) = \frac{1}{R_p} \frac{v_{out}^2}{\Delta f}$$

$$L(\Delta f) = 10 \log \left( \frac{S_{noise}(\Delta f)}{P_{sig}} \right) = 10 \log \left( \frac{2kTF(\Delta f)}{P_{sig}} \left( \frac{1}{2Q} \frac{f_o}{\Delta f} \right)^2 \right)$$

# Example: Active Noise Same as Tank Noise

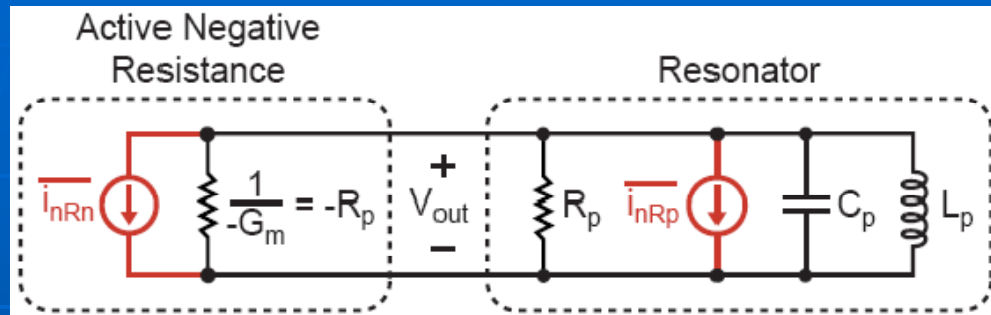

- Assume:

$$F(\Delta f) = 1 + \frac{\overline{i_{nRn}^2}}{\Delta f} / \frac{\overline{i_{nRp}^2}}{\Delta f} = 2$$

- Resulting phase noise

$$L(\Delta f) = 10 \log \left( \frac{4kT}{P_{sig}} \left( \frac{1}{2Q} \frac{f_o}{\Delta f} \right)^2 \right)$$

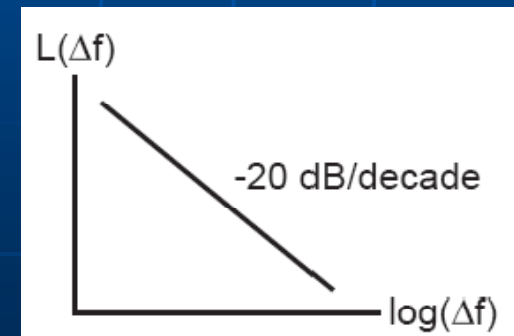

# A More Sophisticated Analysis Method

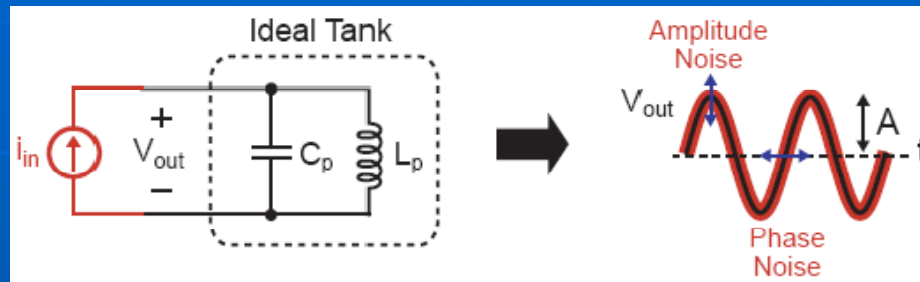

- Our concern is what happens when noise current produces a voltage across the tank
  - Such voltage deviations give rise to both amplitude and phase noise
  - Amplitude noise is suppressed through feedback (or by amplitude limiting in following buffer stages)
    - Our main concern is phase noise

# Modeling of Phase and Amplitude Perturbations

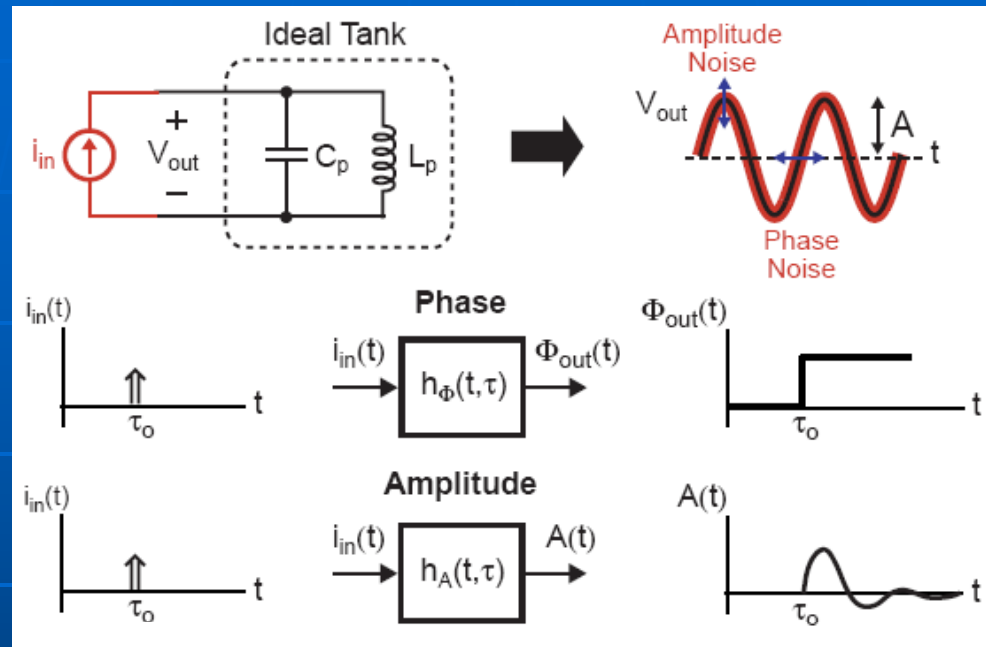

- Modeling of Phase and Amplitude Perturbations
- Characterize impact of current noise on amplitude and phase through their associated impulse responses
  - Phase deviations are accumulated
  - Amplitude deviations are suppressed

# Impact of Noise Current is Time-Varying

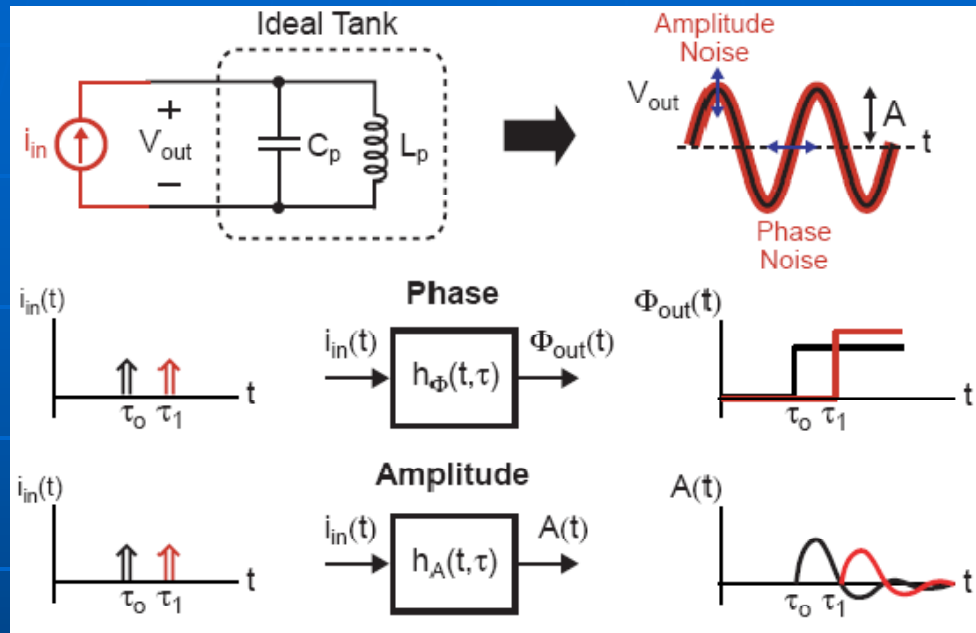

- If we vary the time at which the current impulse is injected, its impact on phase and amplitude changes
  - Need a time-varying model

# Amplitude Perturbations

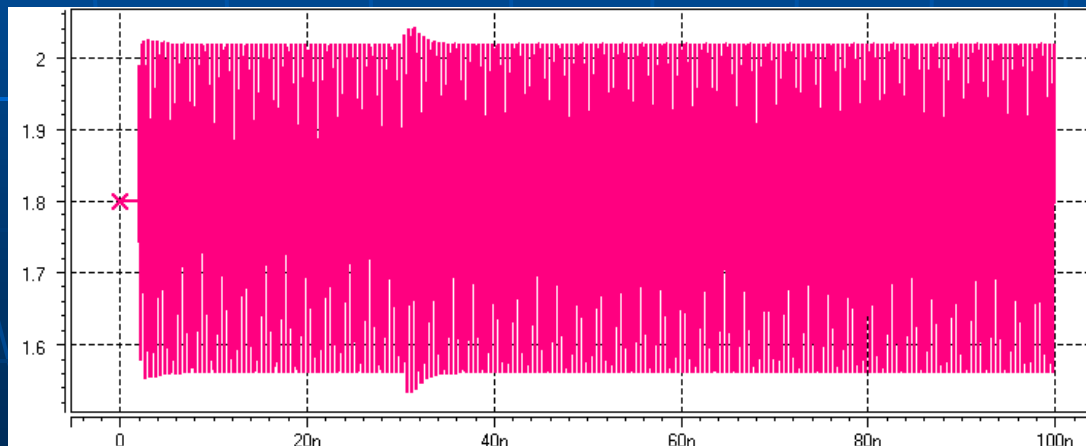
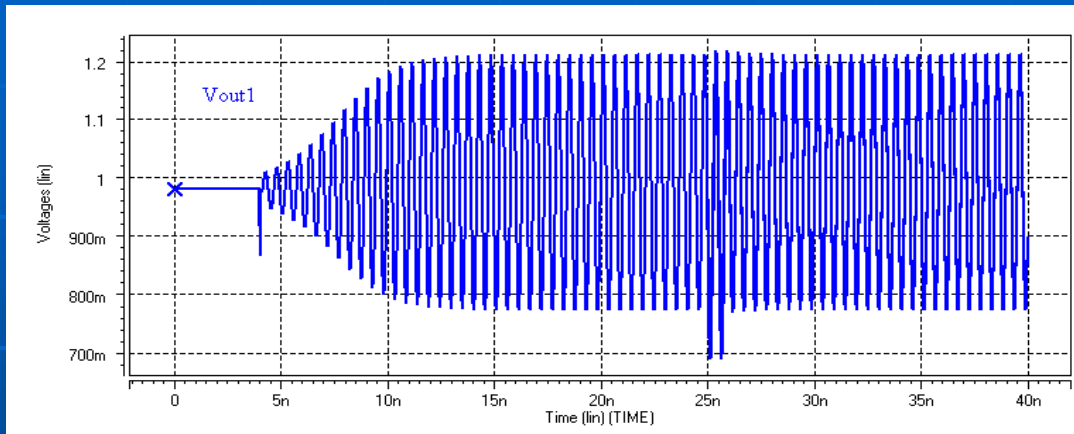

# Noise Impact in Simulation

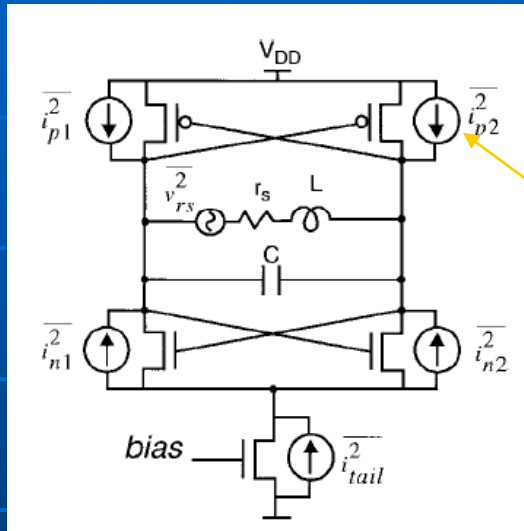

Complementary LC oscillator  
with noise sources

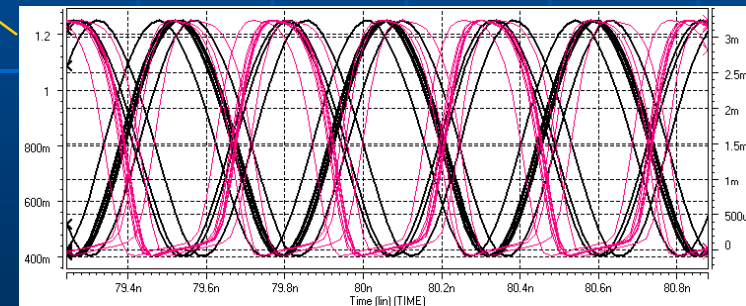
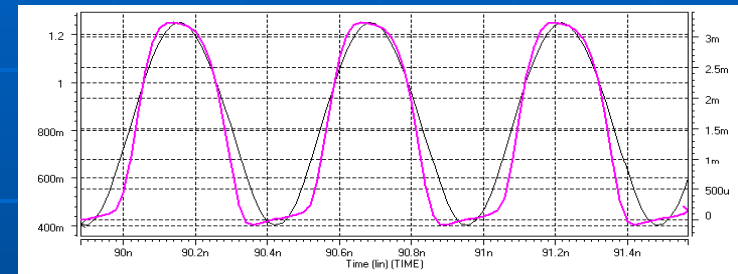



# Illustration of Time-Varying Impact of Noise on Phase

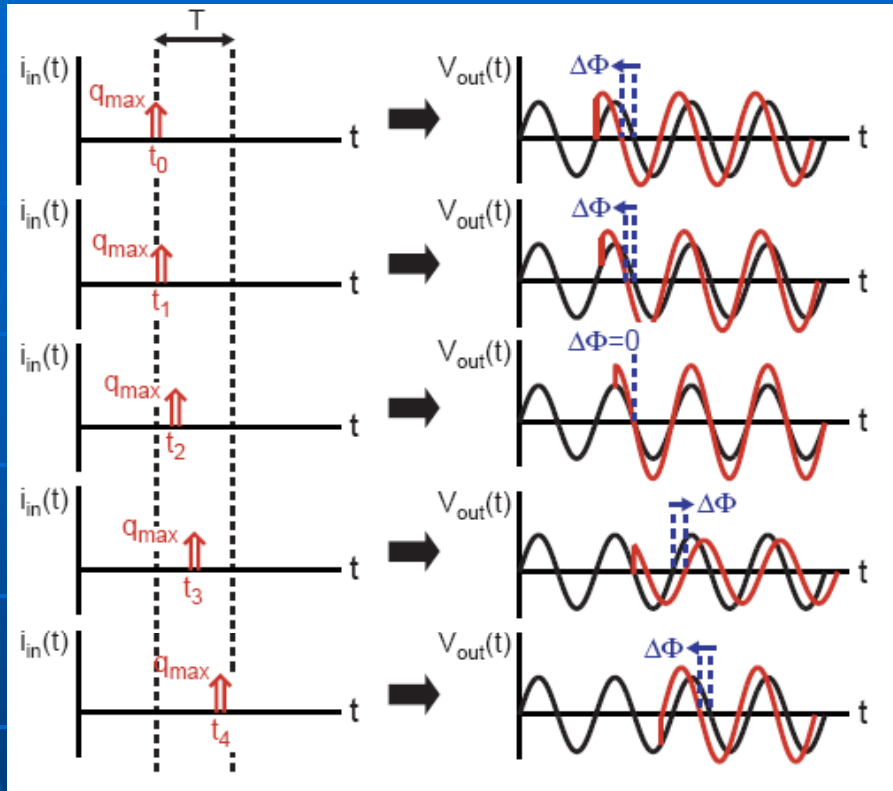

- High impact on phase when impulse occurs close to the zero crossing of the VCO output
- Low impact on phase when impulse occurs at peak of output

# Define Impulse Sensitivity Function (ISF) – $\Gamma(2\pi f_0 t)$

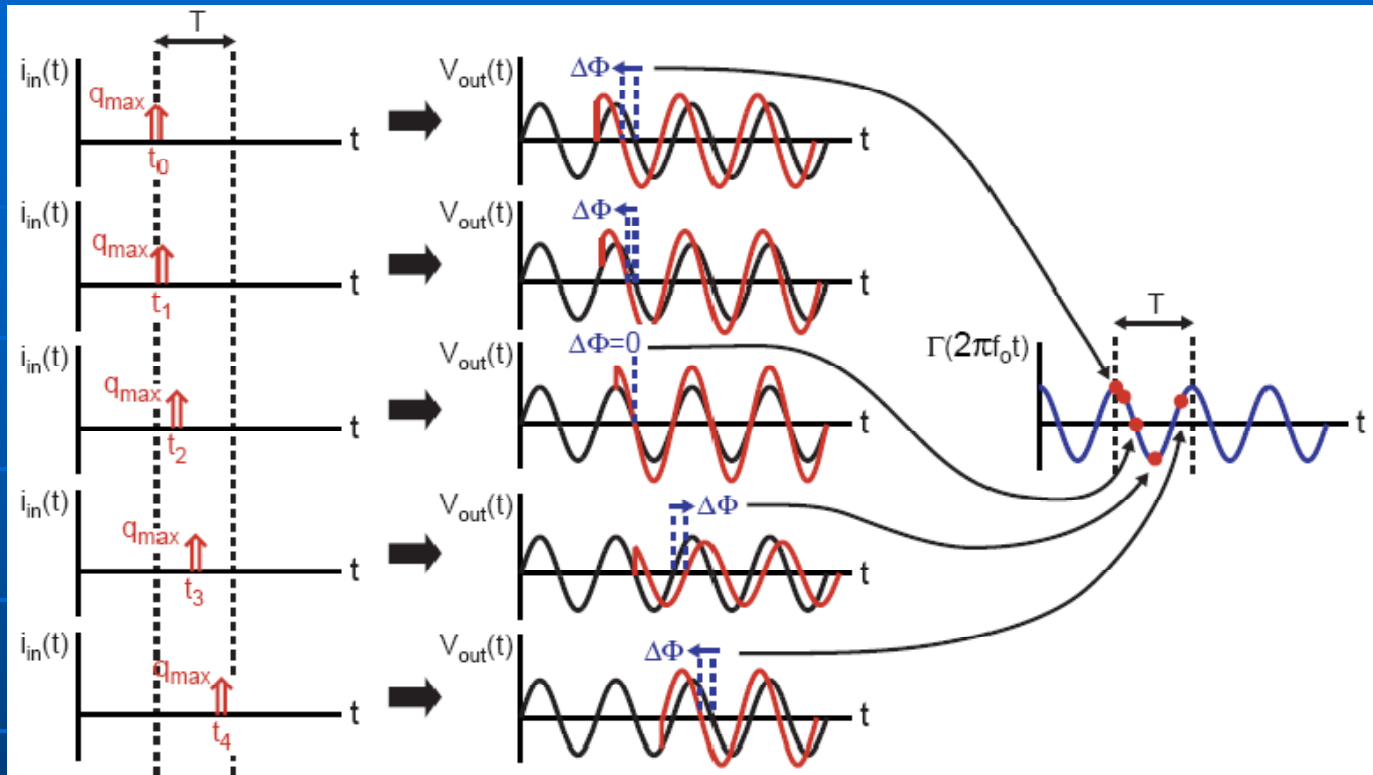

- ISF constructed by calculating phase deviations as impulse position is varied
  - Observe that it is periodic with same period as VCO output

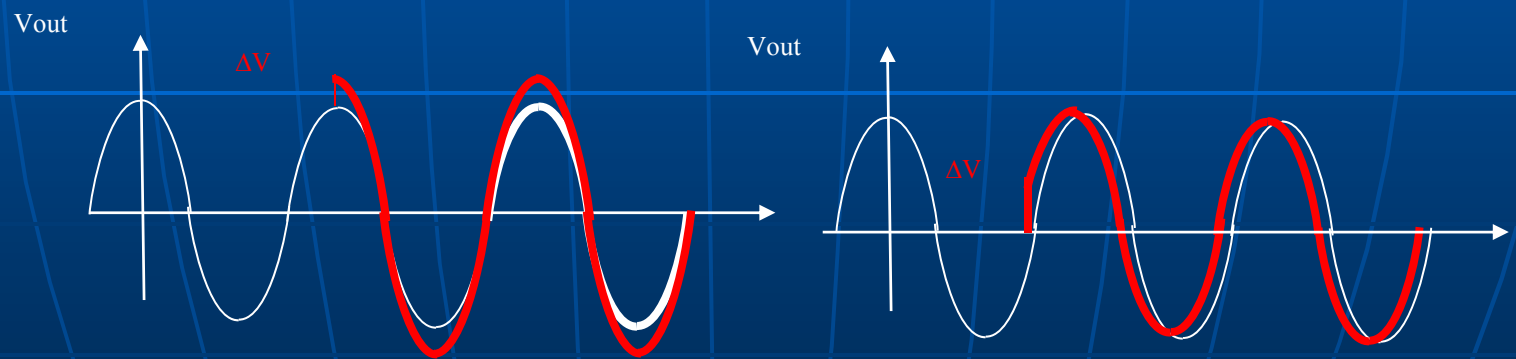
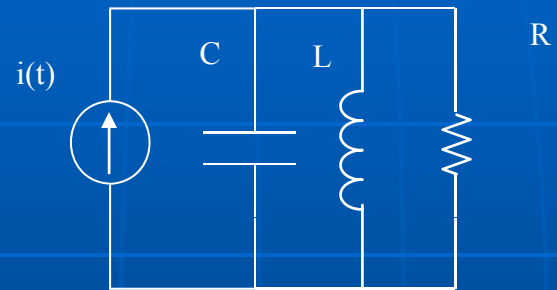

# Parameterize Phase Impulse Response in Terms of ISF

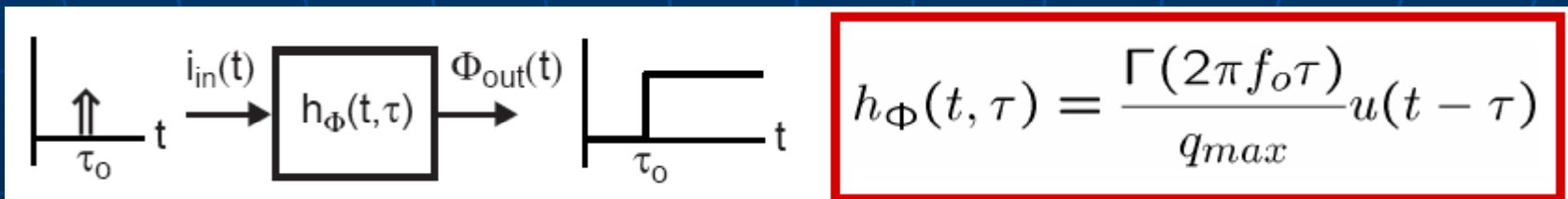
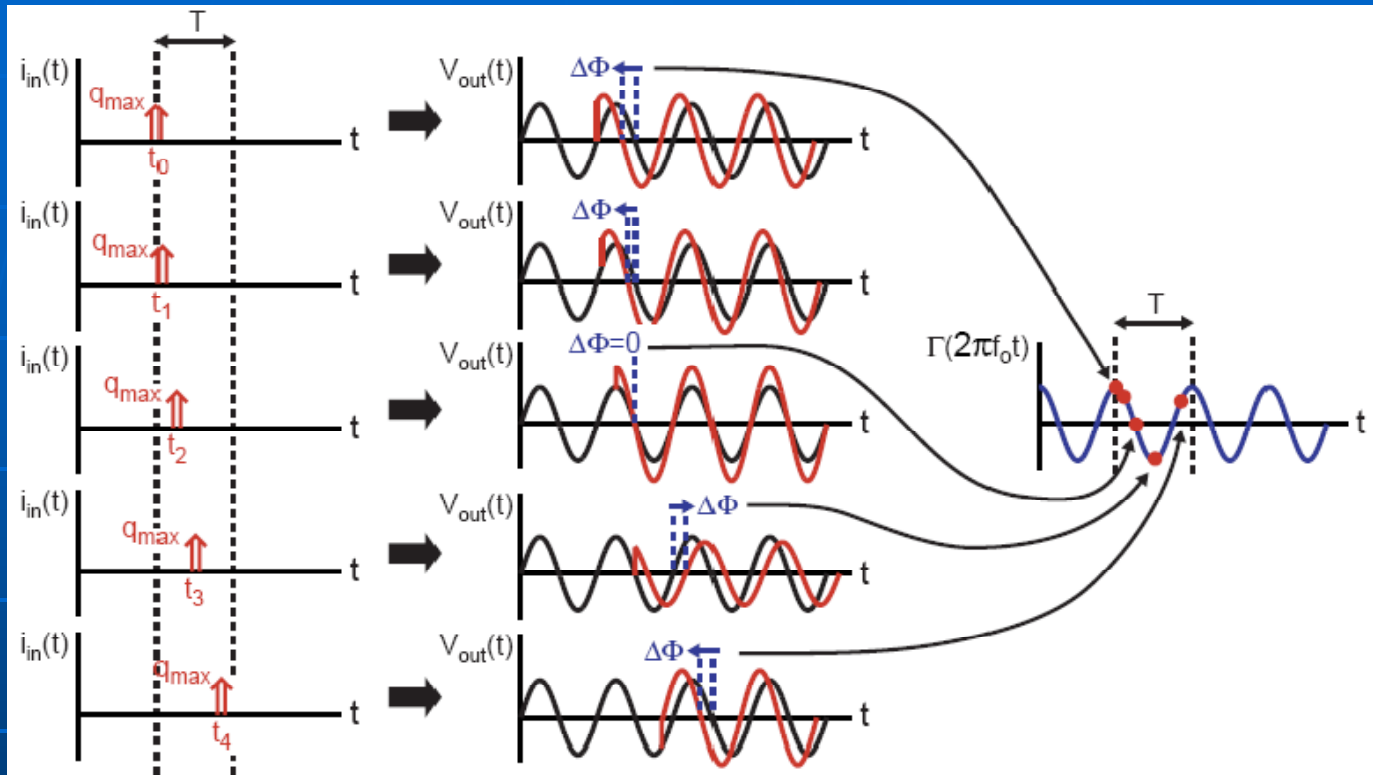

# Linear Property of the Phase Function in Simulation

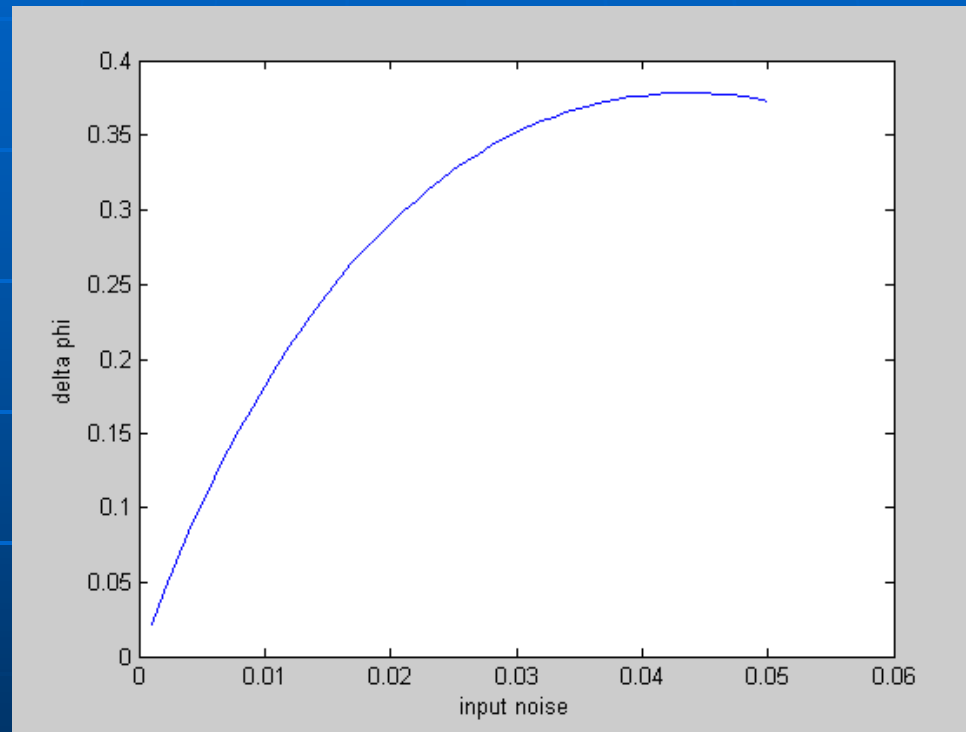

Phase shift versus injected charge for a cross coupled oscillator

# Examples of ISF for Different VCO Output Waveforms

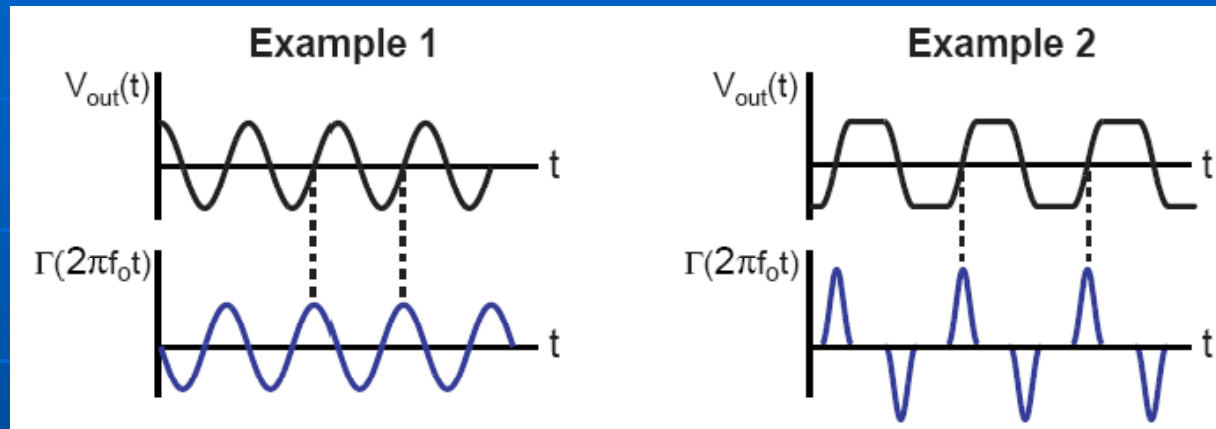

- ISF (i.e.,  $\Gamma$ ) is approximately proportional to derivative of VCO output waveform
  - Its magnitude indicates where VCO waveform is most sensitive to noise current into tank with respect to creating phase noise
- ISF is periodic
- In practice, derive it from simulation of the VCO

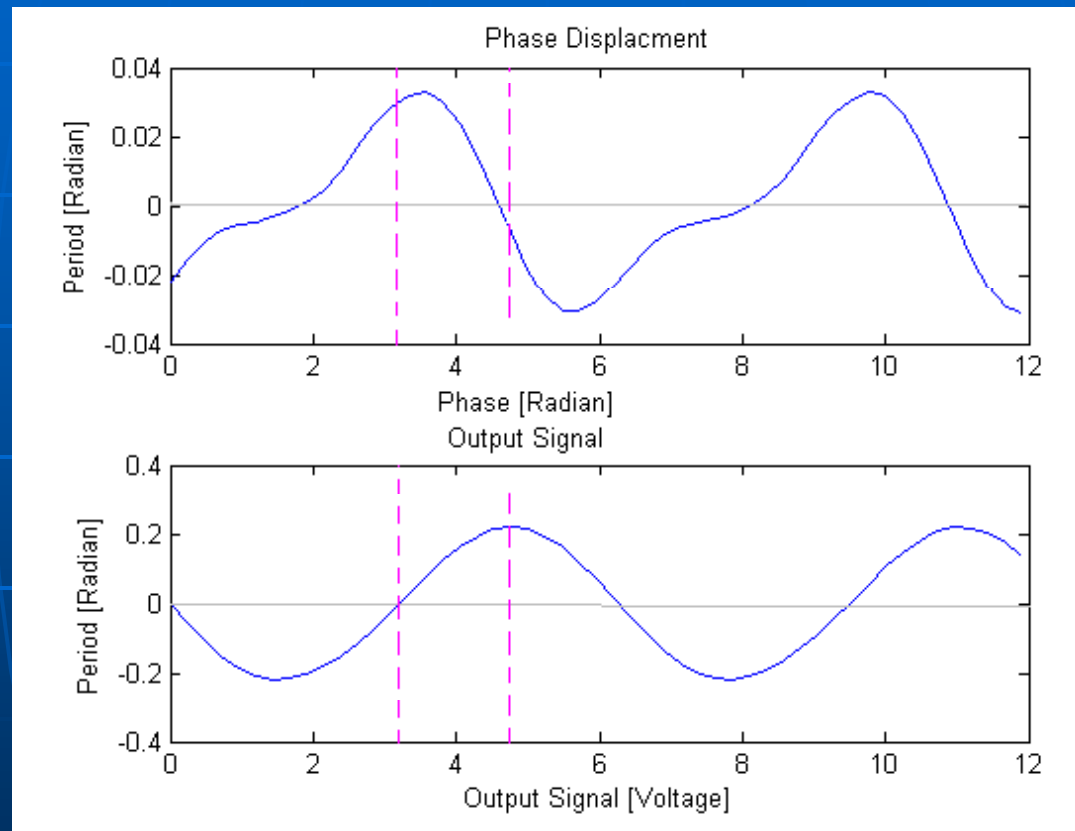

## Excess phase and voltage in the output of cross coupled oscillator

# Phase Noise Analysis Using LTV Framework

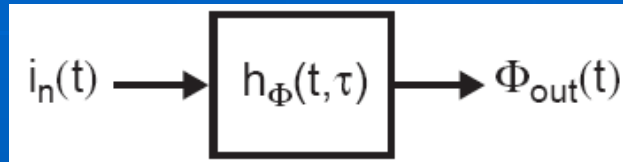

- Computation of phase deviation for an arbitrary noise current input

$$\Phi_{out}(t) = \int_{-\infty}^{\infty} h_{\Phi}(t, \tau) i_n(\tau) d\tau = \frac{1}{q_{max}} \int_{-\infty}^t \Gamma(2\pi f_o \tau) i_n(\tau) d\tau$$

- Analysis simplified if we describe ISF in terms of its Fourier series

$$\Gamma(2\pi f_o \tau) = \frac{c_o}{\sqrt{2}} + \sum_{n=1}^{\infty} c_n \cos(n2\pi f_o \tau + \theta_n)$$

$$\Phi_{out}(t) = \int_{-\infty}^t \left( \frac{c_o}{\sqrt{2}} + \sum_{n=1}^{\infty} c_n \cos(n2\pi f_o \tau + \theta_n) \right) \frac{i_n(\tau)}{q_{max}} d\tau$$



# Block Diagram of LTV Phase Noise Expression

- Noise source distribution based on ac-coupled

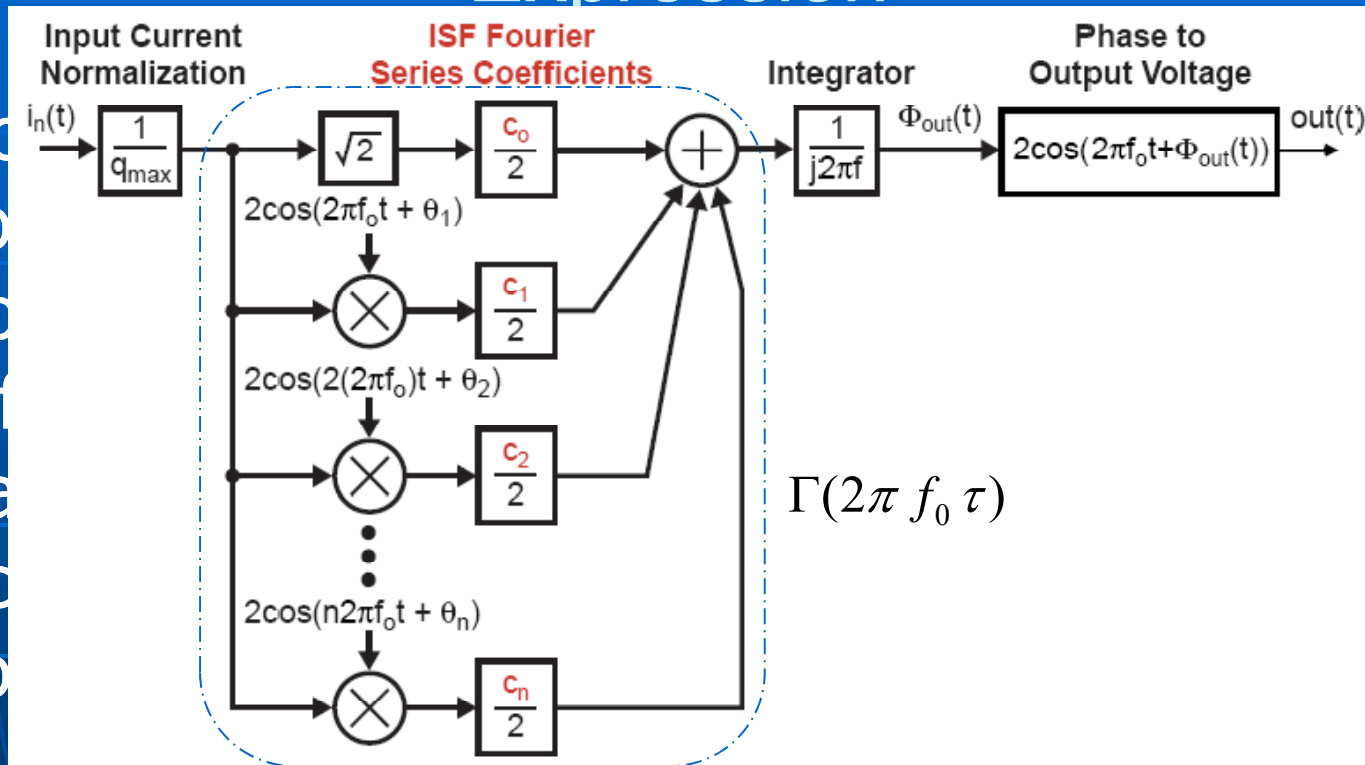

# Phase Noise Calculation for White Noise Input (Part 1)

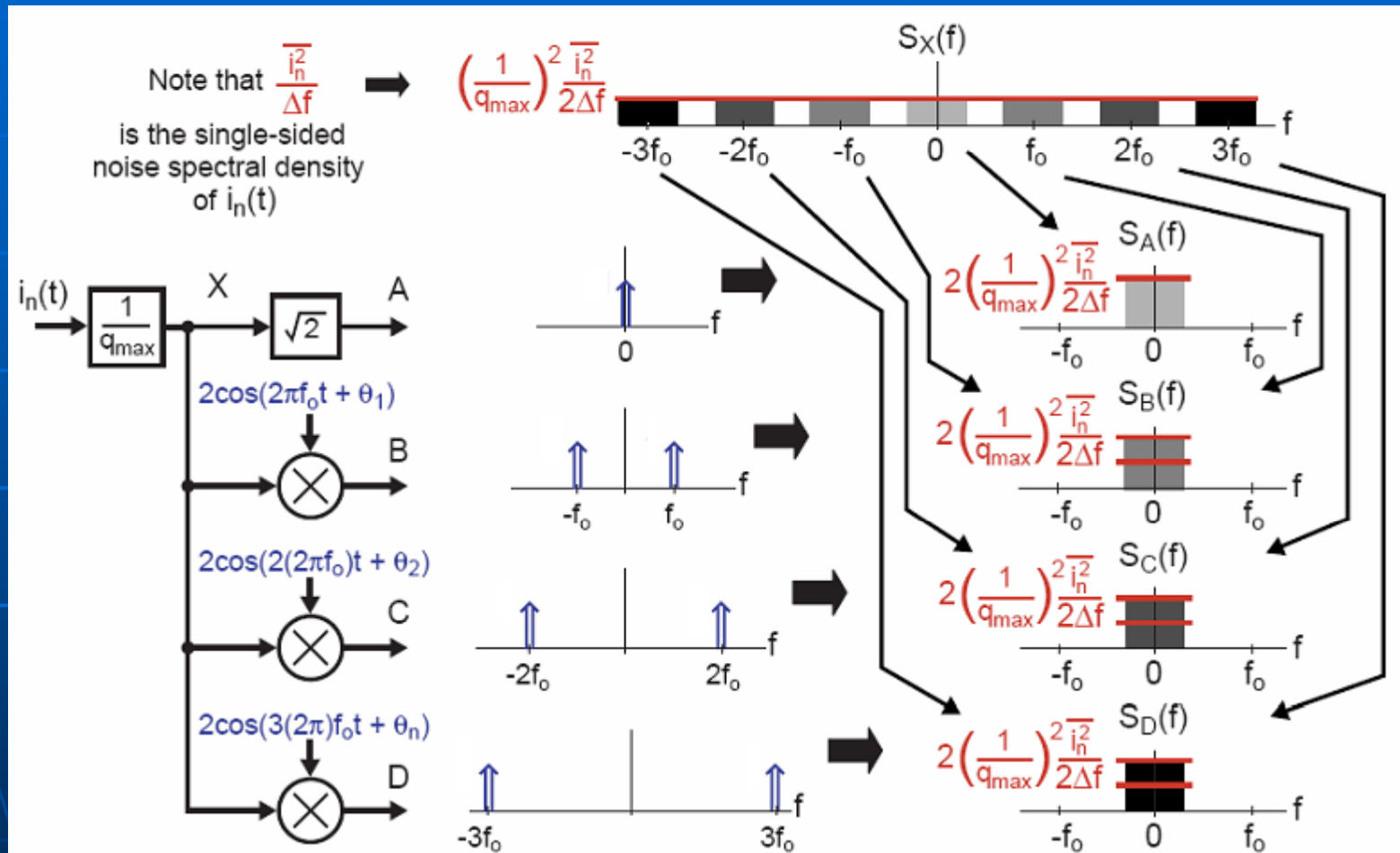

# Phase Noise Calculation for White Noise Input (Part 2)

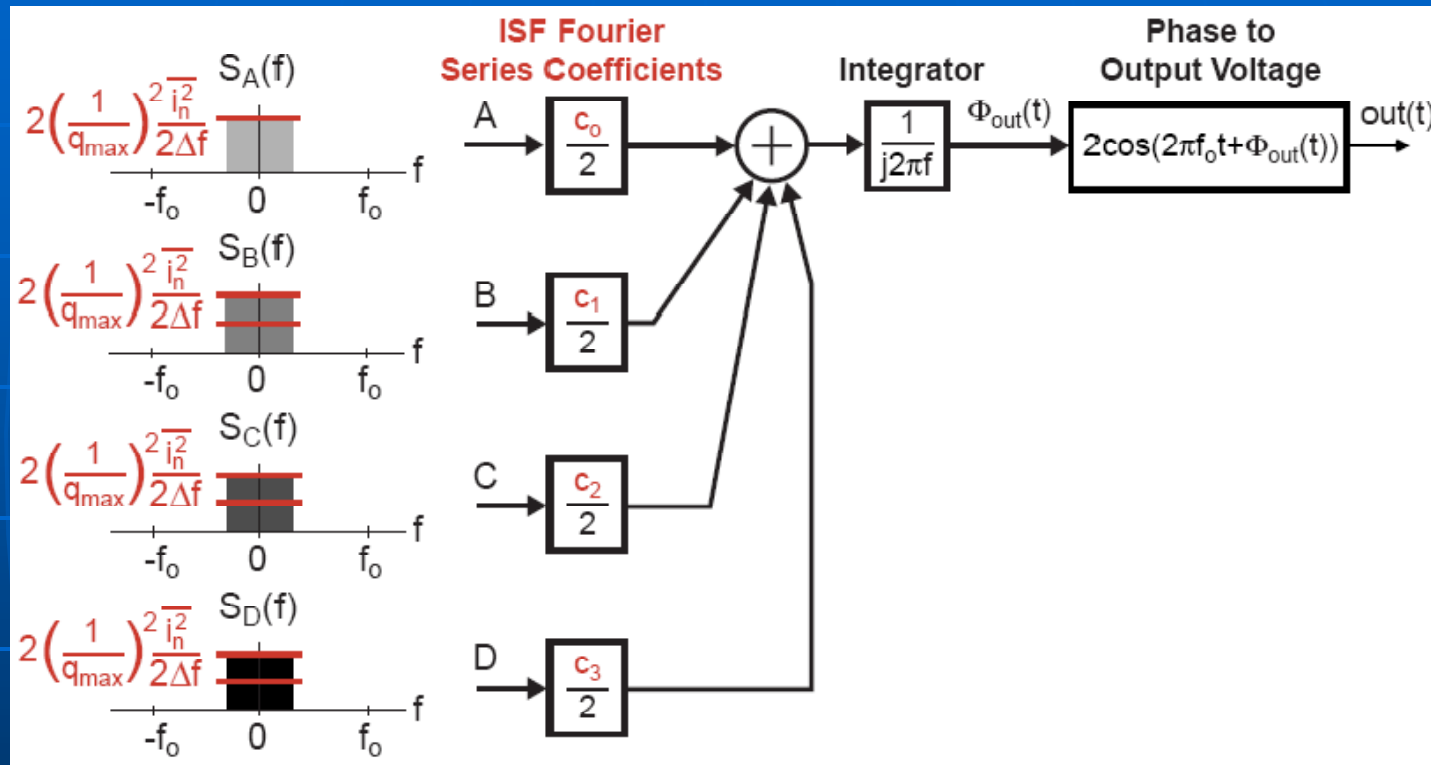

$$S_{\Phi_{out}}(f) = \left| \frac{1}{j2\pi f} \right|^2 \left( \left( \frac{c_0}{2} \right)^2 S_A(f) + \left( \frac{c_1}{2} \right)^2 S_B(f) + \dots \right)$$

# Spectral Density of Phase Signal

- From the previous slide

$$S_{\Phi_{out}}(f) = \left(\frac{1}{2\pi f}\right)^2 \left( \left(\frac{c_0}{2}\right)^2 S_A(f) + \left(\frac{c_1}{2}\right)^2 S_B(f) + \dots \right)$$

- Substitute in for  $S_A(f)$ ,  $S_B(f)$ , etc.

$$S_{\Phi_{out}}(f) = \left(\frac{1}{2\pi f}\right)^2 \left( \left(\frac{c_0}{2}\right)^2 + \left(\frac{c_1}{2}\right)^2 + \dots \right) 2 \left(\frac{1}{q_{max}}\right)^2 \frac{\overline{i_n^2}}{2\Delta f}$$

- Resulting expression

$$S_{\Phi_{out}}(f) = \left(\frac{1}{2\pi f}\right)^2 \left( \sum_{n=0}^{\infty} c_n^2 \right) \frac{1}{4} \left(\frac{1}{q_{max}}\right)^2 \frac{\overline{i_n^2}}{\Delta f}$$

# Output Phase Noise

- We now know

$$S_{\Phi_{out}}(f) = \left| \frac{1}{2\pi f} \right|^2 \left( \sum_{n=0}^{\infty} c_n^2 \right) \frac{1}{4} \left( \frac{1}{q_{max}} \right)^2 \frac{\overline{i_n^2}}{\Delta f}$$
$$L(\Delta f) = 10 \log(S_{\Phi_{out}}(\Delta f))$$

- Resulting phase noise

$$L(\Delta f) = 10 \log \left( \left( \frac{1}{2\pi \Delta f} \right)^2 \left( \sum_{n=0}^{\infty} c_n^2 \right) \frac{1}{4} \left( \frac{1}{q_{max}} \right)^2 \frac{\overline{i_n^2}}{\Delta f} \right)$$

# The Impact of 1/f Noise in Input Current (Part 1)

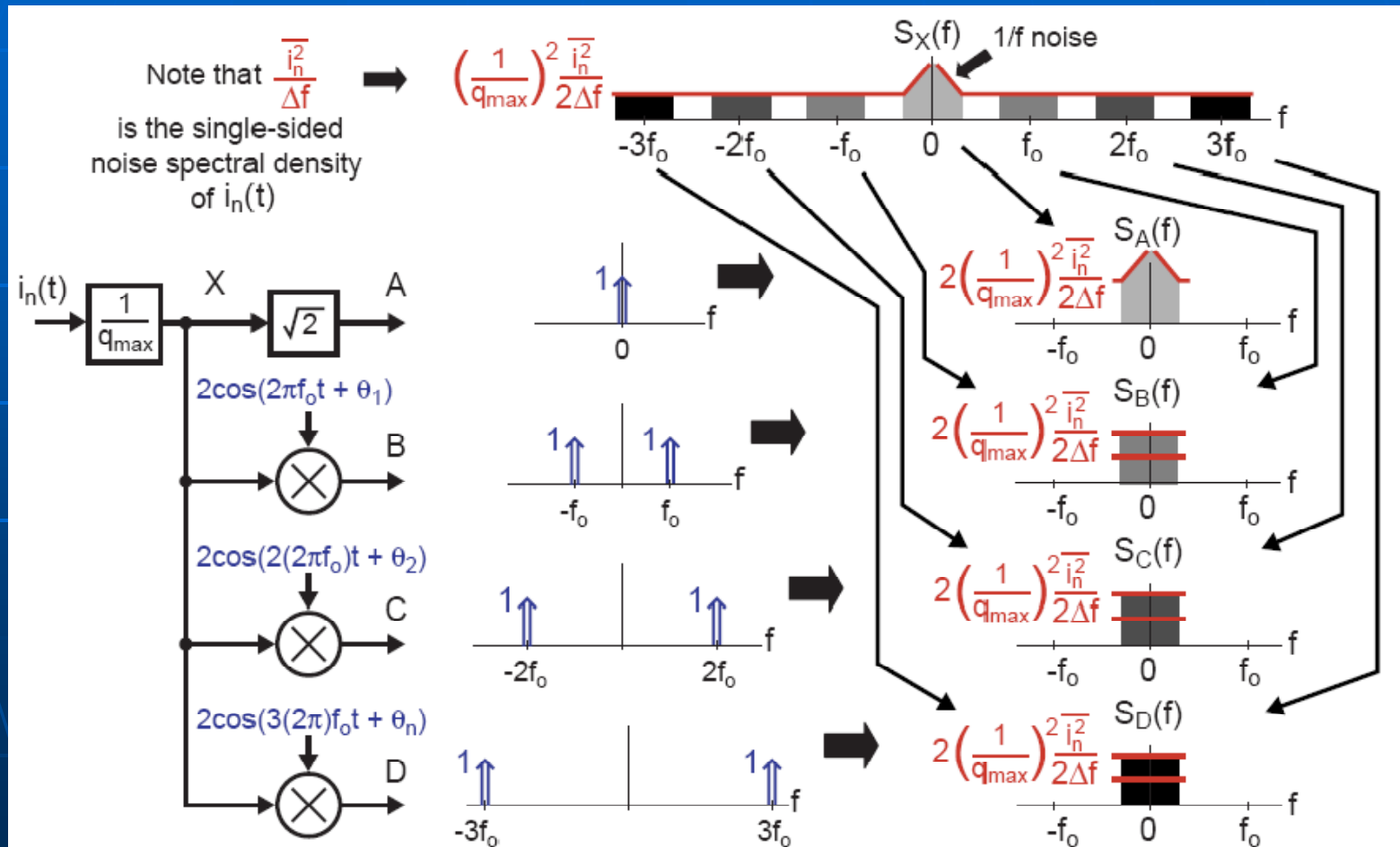

# The Impact of 1/f Noise in Input Current (Part 2)

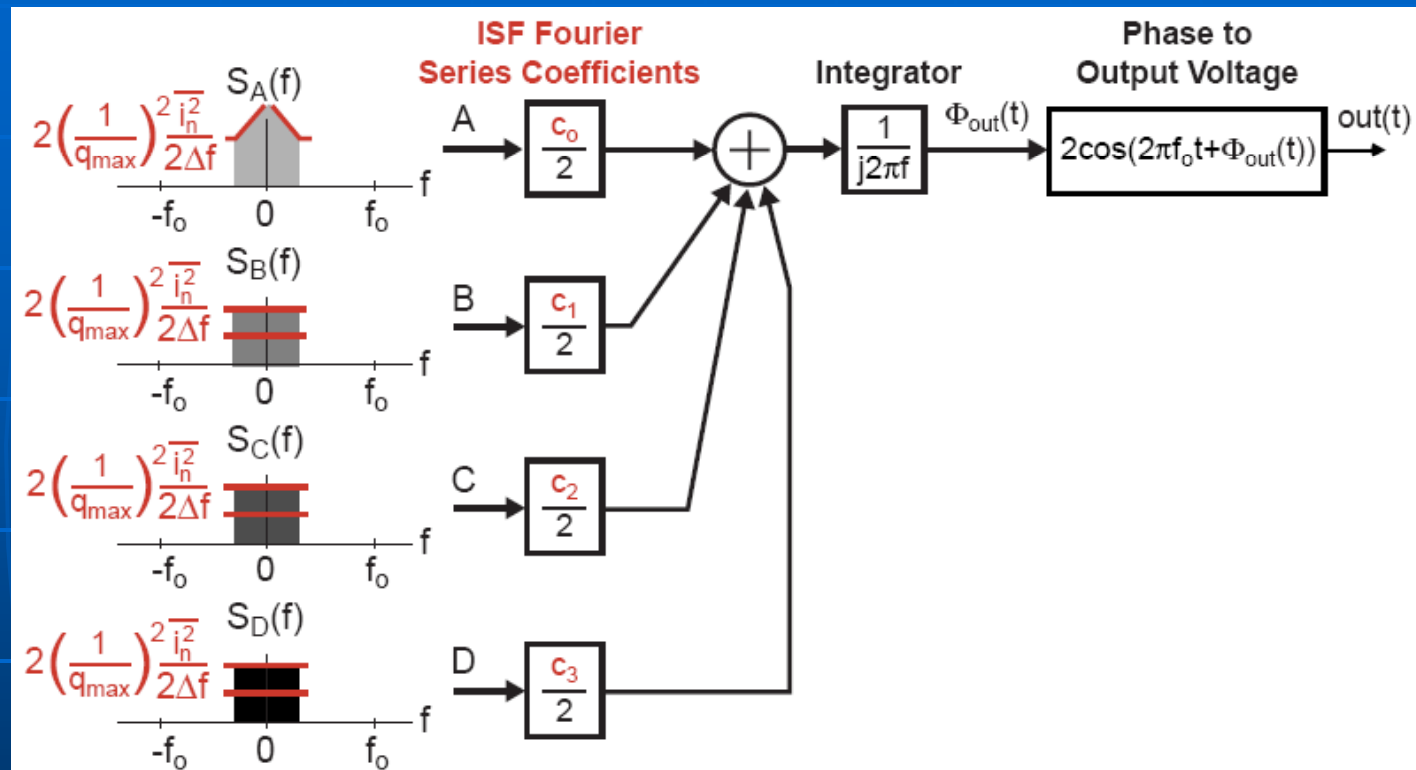

$$S_{\Phi_{out}}(f) \Big|_{1/f^3} = \left| \frac{1}{j2\pi f} \right|^2 \left( \frac{c_0}{2} \right)^2 S_A(f)$$

# Calculation of Output Phase Noise in $1/f^3$ region

- From the previous slide

$$S_{\Phi_{out}}(f) \Big|_{1/f^3} = \left(\frac{1}{2\pi f}\right)^2 \left(\frac{c_o}{2}\right)^2 S_A(f)$$

- Assume that input current has  $1/f$  noise with corner frequency  $f_{1/f}$

$$S_A(f) = \left(\frac{1}{q_{max}}\right)^2 \frac{\overline{i_n^2}}{\Delta f} \left(\frac{f_{1/f}}{\Delta f}\right)$$

- Corresponding output phase noise

$$L(\Delta f) \Big|_{1/f^3} = 10 \log \left( \left(\frac{1}{2\pi \Delta f}\right)^2 \left(\frac{c_o}{2}\right)^2 S_A(f) \right)$$

$$= 10 \log \left( \left(\frac{1}{2\pi \Delta f}\right)^2 (c_o^2) \frac{1}{4} \left(\frac{1}{q_{max}}\right)^2 \frac{\overline{i_n^2}}{\Delta f} \left(\frac{f_{1/f}}{\Delta f}\right) \right)$$



# Calculation of $1/f^3$ Corner Frequency

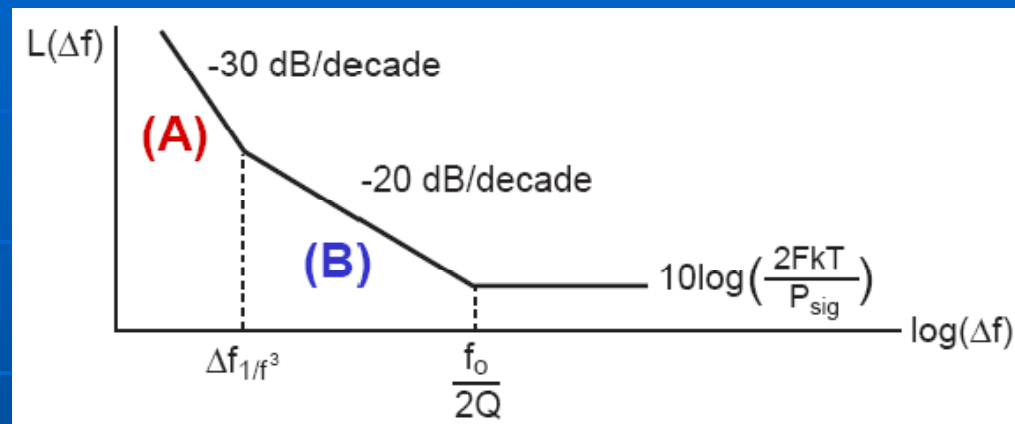

$$(A) \quad L(\Delta f) \Big|_{1/f^3} = 10 \log \left( \left( \frac{1}{2\pi \Delta f} \right)^2 (c_o^2) \frac{1}{4} \left( \frac{1}{q_{max}} \right)^2 \frac{\overline{i_n^2}}{\Delta f} \left( \frac{f_{1/f}}{\Delta f} \right) \right)$$

$$(B) \quad L(\Delta f) = 10 \log \left( \left( \frac{1}{2\pi \Delta f} \right)^2 \left( \sum_{n=0}^{\infty} c_n^2 \right) \frac{1}{4} \left( \frac{1}{q_{max}} \right)^2 \frac{\overline{i_n^2}}{\Delta f} \right)$$

$$(A) = (B) \text{ at: } \Rightarrow \Delta f_{1/f^3} = \left( c_o^2 / \sum_{n=0}^{\infty} c_n^2 \right) f_{1/f}$$

# Impact of Oscillator Waveform on $1/f^3$ Phase Noise

*ISF for Symmetric Waveform*

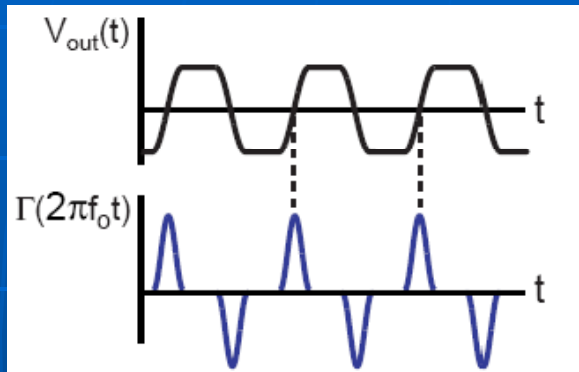

*ISF for Asymmetric Waveform*

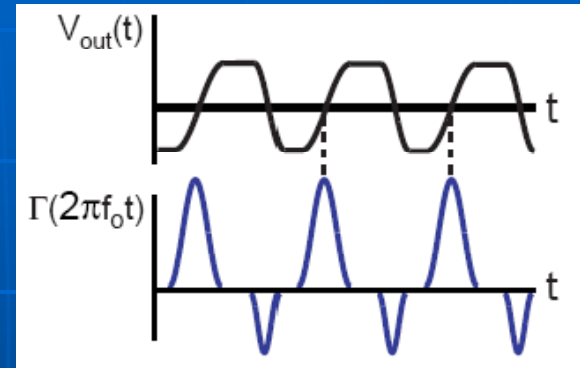

- Key Fourier series coefficient of ISF for  $1/f^3$  noise is  $c_0$ 
  - If DC value of ISF is zero,  $c_0$  is also zero
- For symmetric oscillator output waveform
  - DC value of ISF is zero - no up-conversion of flicker noise! (i.e. output phase noise does not have  $1/f^3$  region)
- For asymmetric oscillator output waveform
  - DC value of ISF is non-zero - flicker noise has impact

## Issue – We Have Ignored Modulation of Current Noise

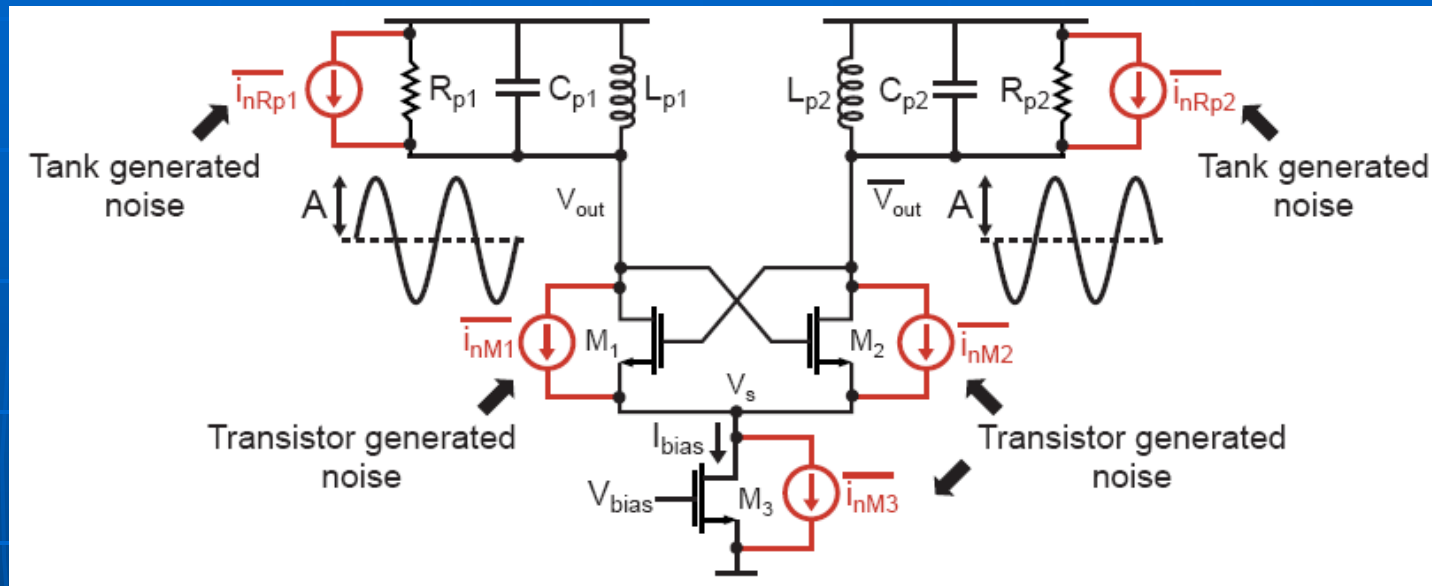

- In practice, transistor generated noise is modulated by the varying bias conditions of its associated transistor
  - As transistor goes from saturation to triode to cutoff, its associated noise changes dramatically
- Can we include this issue in the LTV framework?

# Inclusion of Current Noise Modulation

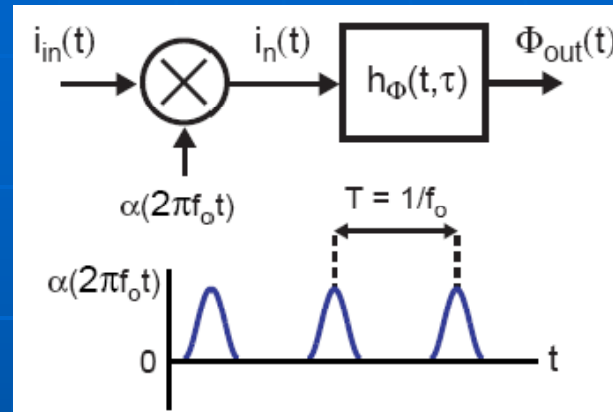

- Recall

$$\Phi_{out}(t) = \int_{-\infty}^{\infty} h_{\Phi}(t, \tau) i_n(\tau) d\tau = \frac{1}{q_{max}} \int_{-\infty}^t \Gamma(2\pi f_o \tau) i_n(\tau) d\tau$$

- By inspection of figure

$$\Phi_{out}(t) = \frac{1}{q_{max}} \int_{-\infty}^t \Gamma(2\pi f_o \tau) \alpha(2\pi f_o \tau) i_{in}(\tau) d\tau$$

- We therefore apply previous framework with ISF as

$$\Gamma_{eff}(2\pi f_o \tau) = \Gamma(2\pi f_o \tau) \alpha(2\pi f_o \tau)$$

# Noise Modulation in Simulation

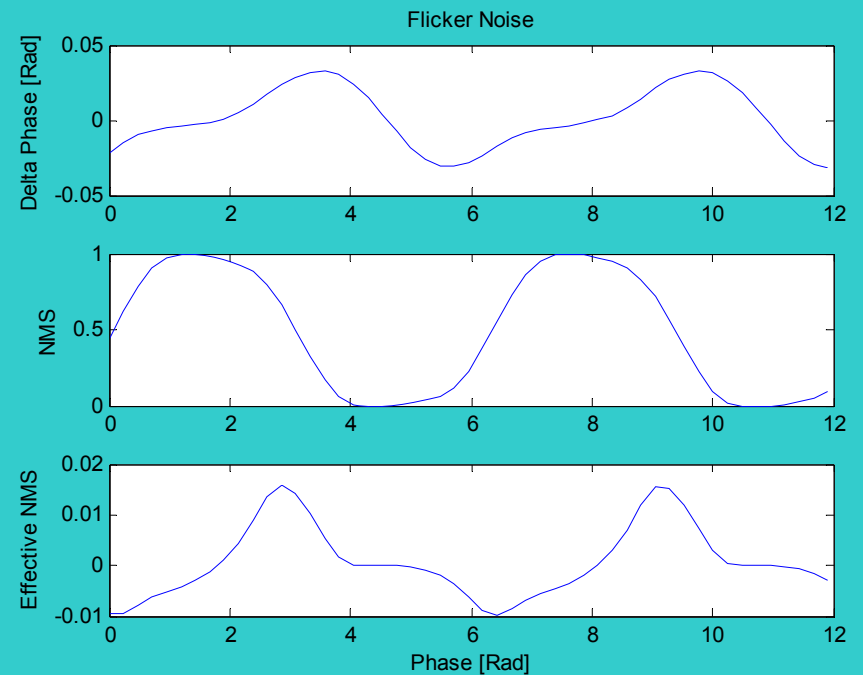
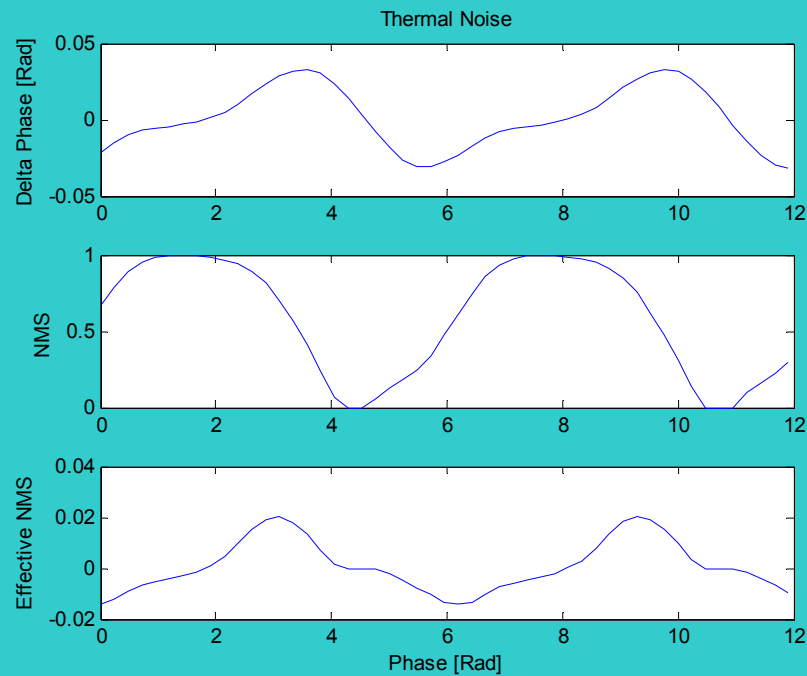

ISF, NMF, and effective ISF waveforms of cross coupled oscillator

# Placement of Current Modulation for Best Phase Noise

*Best Placement of Current Modulation for Phase Noise*

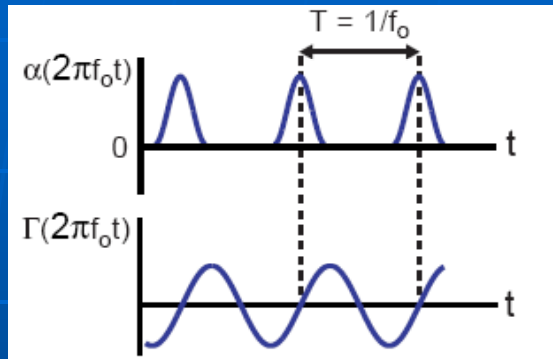

*Worst Placement of Current Modulation for Phase Noise*

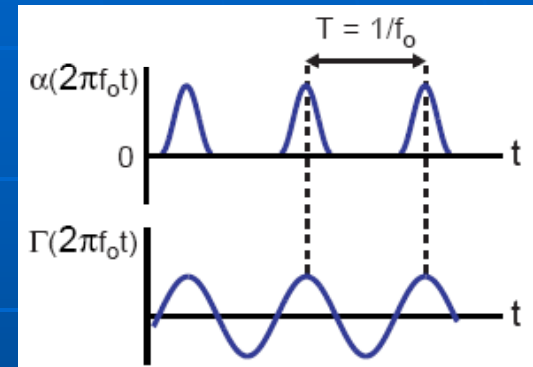

- Phase noise expression (ignoring 1/f noise)

$$L(\Delta f) = 10 \log \left( \left( \frac{1}{2\pi\Delta f} \right)^2 \left( \sum_{n=0}^{\infty} c_n^2 \right) \frac{1}{4} \left( \frac{1}{q_{max}} \right)^2 \frac{\overline{i_n^2}}{\Delta f} \right)$$

- Minimum phase noise achieved by minimizing sum of square of Fourier series coefficients (i.e. rms value of  $\Gamma_{eff}$ )

# Colpitts Oscillator Provides Optimal Placement of $\alpha$

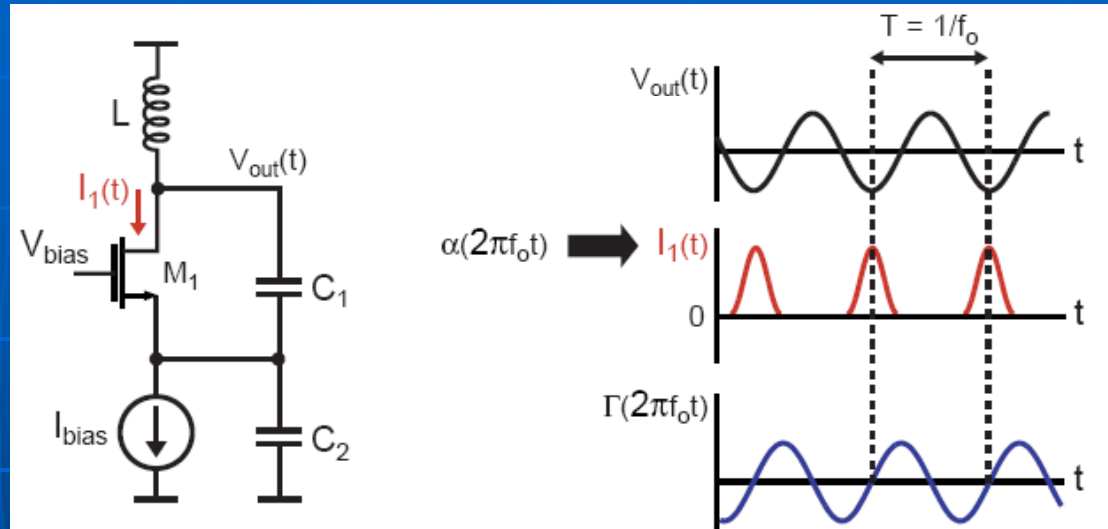

- Current is injected into tank at bottom portion of VCO swing
  - Current noise accompanying current has minimal impact on VCO output phase

# Noise Modulation in Collpits

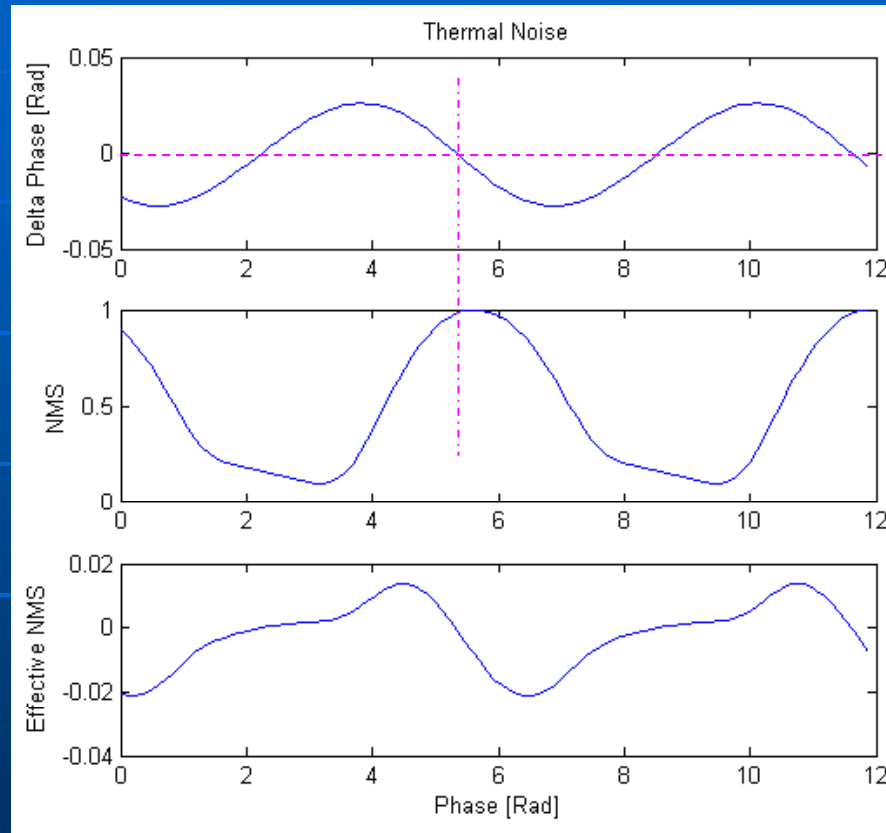

ISF, NMF, and effective ISF waveforms of colpitts oscillator



# Summary of LTV Phase Noise Analysis Method

- Step 1: calculate the impulse sensitivity function of each oscillator noise source using a simulator
- Step 2: calculate the noise current modulation waveform for each oscillator noise source using a simulator
- Step 3: combine above results to obtain  $\Gamma_{\text{eff}}(2\pi f_0 t)$  for each oscillator noise source
- Step 4: calculate Fourier series coefficients for each  $\Gamma_{\text{eff}}(2\pi f_0 t)$
- Step 5: calculate spectral density of each oscillator noise source
- Step 6: calculate overall output phase noise using the results from

# Outline

- Introduction
- Phase Noise
- Output Phase Noise Spectrum
- On chip Inductors
- Advanced On Chip Inductor

# On chip Inductors

- In contrast with digital circuits which use mainly active devices, on-chip passive components are necessary and imperative adjuncts to most RF electronics. These components include inductors, capacitors, varactors, and resistors
- For example, the Nokia 6161 cellphone contains 15 IC's with 232 capacitors, 149 resistors, and 24 inductors
- Inductors in particular are critical components in low noise amplifiers, oscillators.
- The lack of an accurate and scalable model for on-chip spiral inductors presents a challenging problem for RF IC's designers

# Quality Factor and Self-Resonant Frequency

The quality factor  $Q$  is an extremely important figure of merit for the inductor at high frequencies. The most fundamental definition for  $Q$  is

$$Q = \omega \cdot \left( \frac{\text{Energy Stored}}{\text{Average Power Dissipated}} \right)$$

Basically, it describes how good an inductor can work as an energy-storage element.

Self-resonant frequency  $f_{SR}$  marks the point where the inductor turns to capacitive.

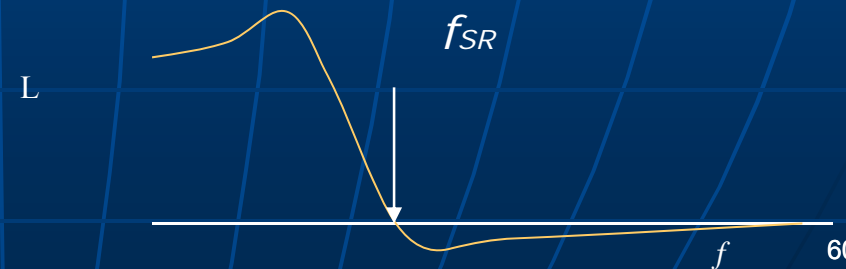

# Off chip resonator properties:

- Highest Q.
- Interfacing from on chip active devices to off chip tank circuits at frequencies in GHz range is quite difficult.
- Consume valuable board space.
- Application example: below 1GHz.

# Inductor's Structures

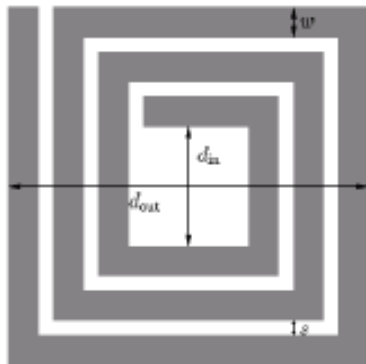

(a) Square Spiral

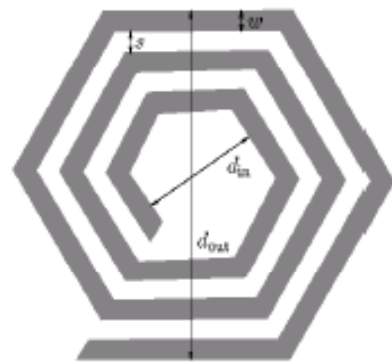

(b) Hexagonal Spiral

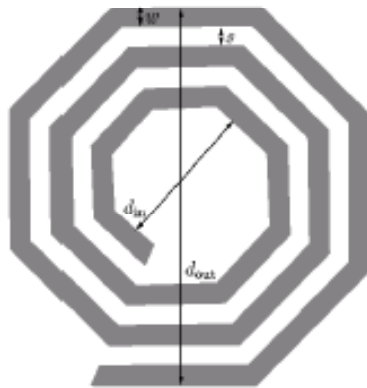

(c) Octagonal Spiral

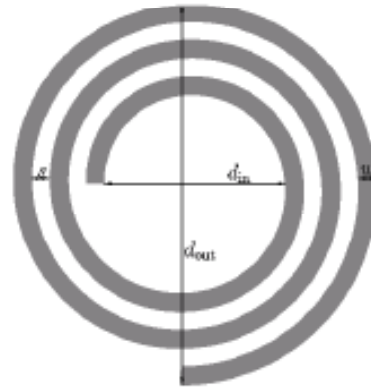

(d) Circular Spiral

For hexagonal and octagonal inductors, less metal length is needed to achieve the same number of turns. Thus series resistance is compressed and Q factor improved.

On the other hand, the square shaped inductor will be more area efficient.

For example, for a square area on the wafer, square shape will utilize 100% of the area, whereas hexagonal, octagonal and circular shapes use 65%, 82.8% and 78.5% respectively

# Typical Square Shaped Spiral Inductor built on Si Substrate

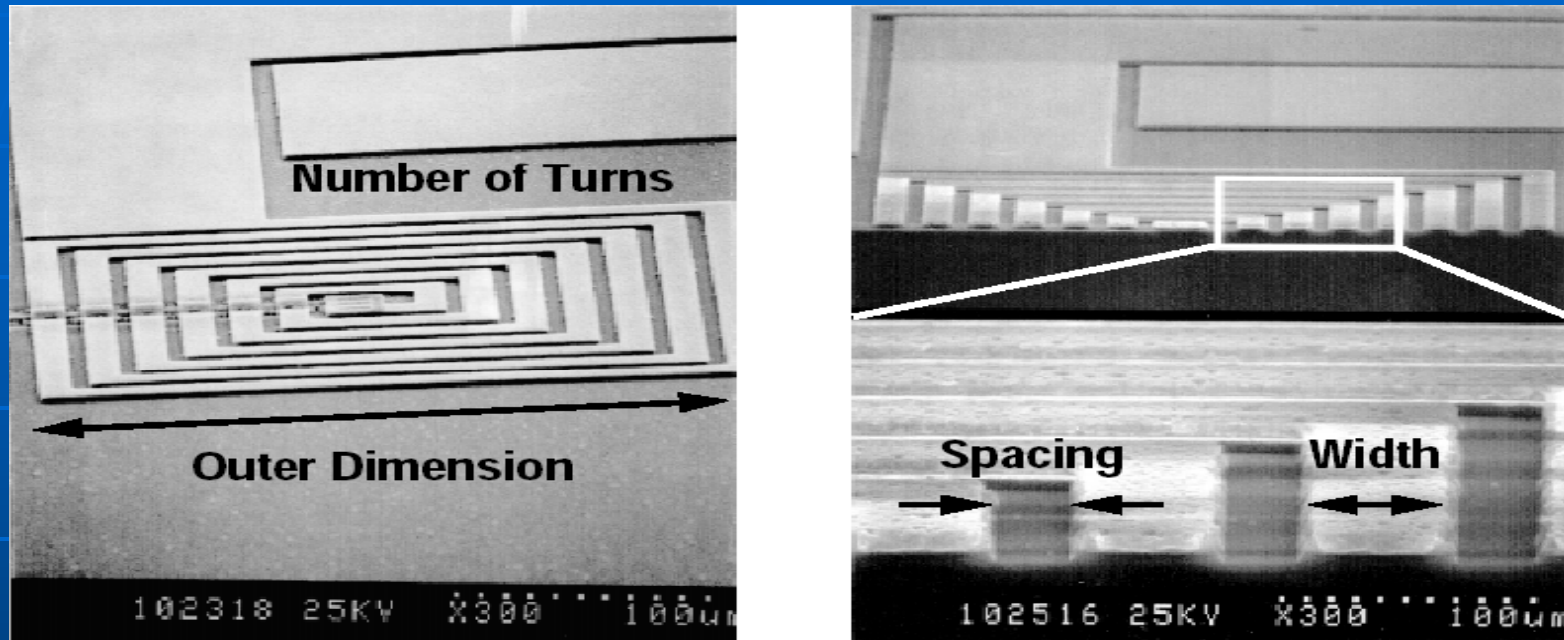

- On-chip spiral inductors are used when a relatively small inductance (i.e., several nH) is needed. Otherwise off-chip inductors are used
- Performance of the spiral inductor depends on the number of turns, line width, spacing, pattern shape, number of metal layers, oxide thickness and conductivity of substrate

# Green House Method

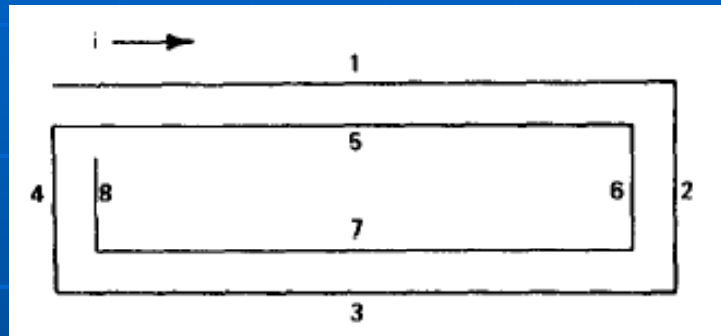

$$L_T = L_1 + L_2 + L_3 + L_4 + L_5 + L_6 + L_7 + L_8 + 2(M_{1,5} + M_{2,6} + M_{3,7} + M_{4,8}) - 2(M_{1,7} + M_{1,3} + M_{5,7} + M_{5,3} + M_{2,8} + M_{2,4} + M_{6,8} + M_{6,4}).$$

$$L_T = L_0 + \Sigma M$$



# Equivalent Circuit of a Lumped (Single- $\pi$ ) Model for Spiral Inductors

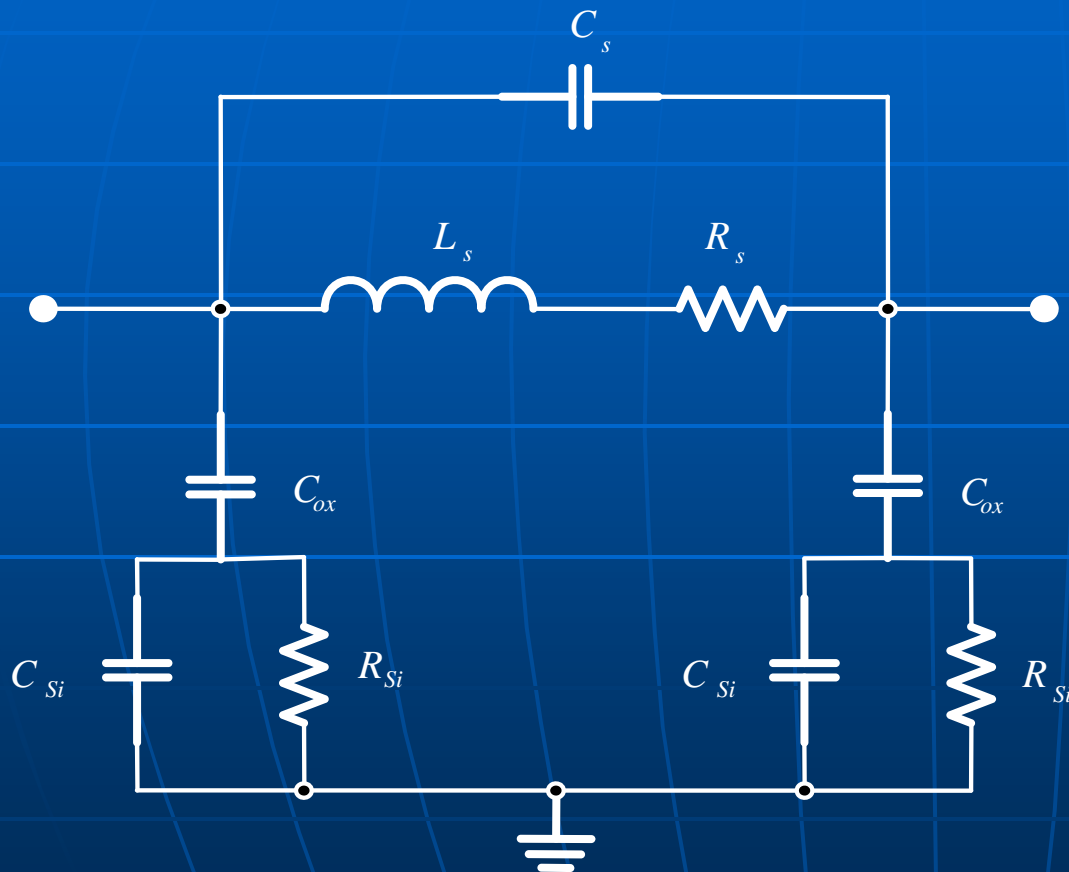

Except for the series inductance, all components in the model are parasitics of the inductor and need to be minimized

This model is widely used, but it is not very accurate and not scalable

# Components of Lumped Model

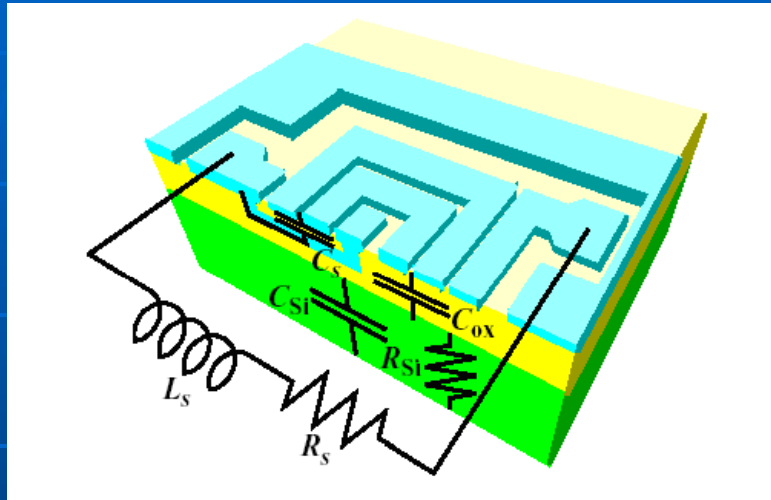

$L_s$  consists of the self inductance, positive mutual inductance, and negative mutual inductance

$C_s$  is the capacitance between metal lines

$R_s$  is the series resistance of the metal line

$C_{ox}$  is the capacitance of oxide layer underneath the spiral

$R_{si}$  and  $C_{si}$  are the coupling resistance and capacitance associated with Si substrate

# Outline

- Introduction
- Phase Noise
- Output Phase Noise Spectrum
- On chip Inductors
- **Advanced On Chip Inductor**

# Structure with patterned ground shield

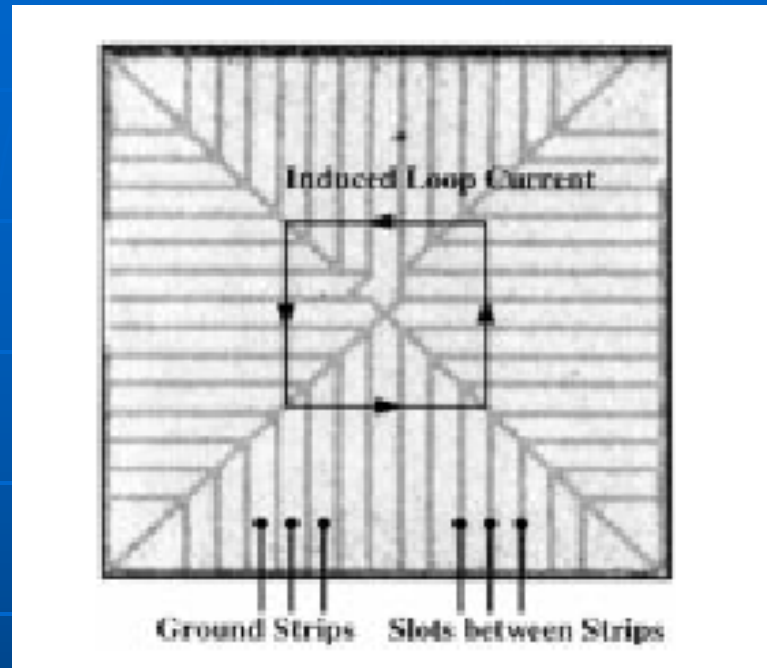

- Ground shielding reduces the effective distance between the spiral and ground and thus reduces the substrate resistance.
- Solid ground shield (SGS) can reflect **EM field** in the substrate and reduce Q factor.  **Patterned ground shield (PGS)**.
- **Drawback:** increase coupling capacitance due to an reduced distance between the metal and ground.

# Structure with Suspended Spiral

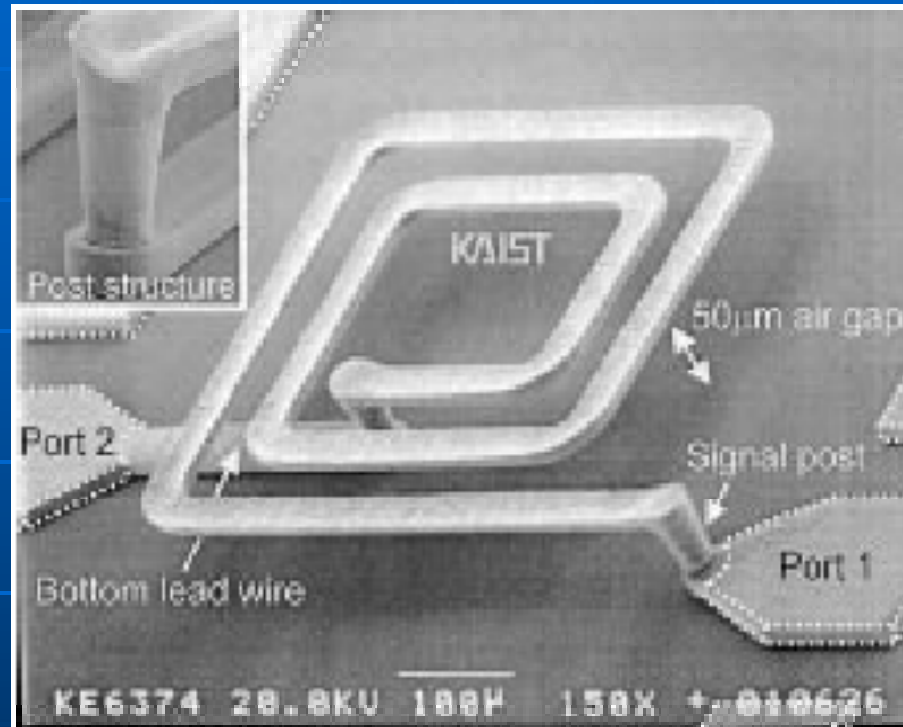

Inductor suspended above the structure to reduce the substrate coupling resistance and capacitance

# Structure with Substrate Removal

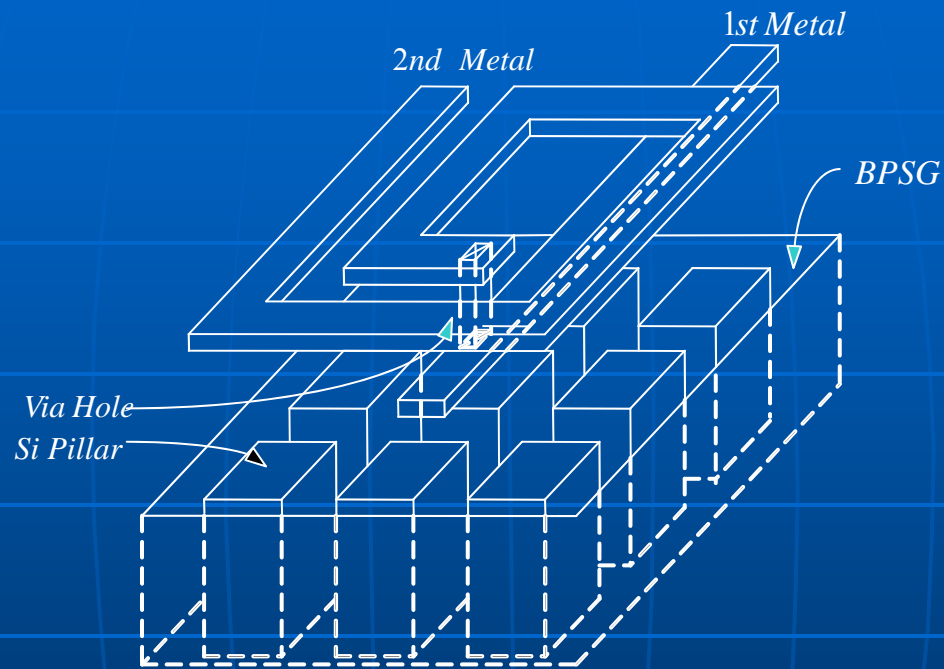

Portions of substrate are moved using deep-trench technology to reduce the substrate coupling resistance and capacitance.

# Structure with Vertical Spiral

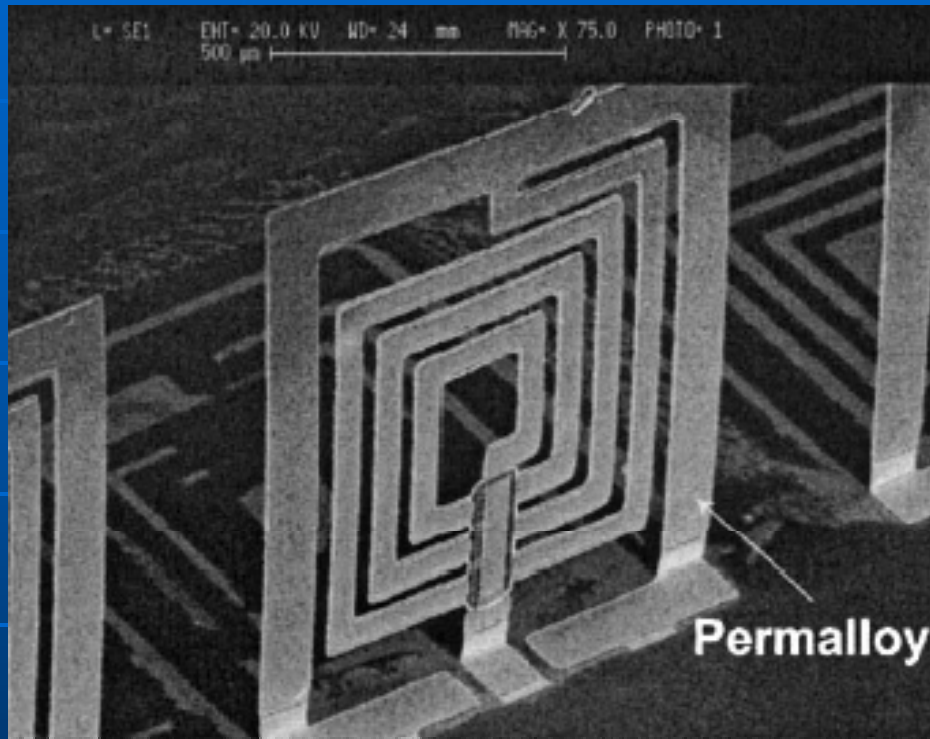

Spiral is placed vertically on the substrate to reduce magnetic field coupling to substrate.

# Structure with Multiple Metal Layers and Vertical Shunt

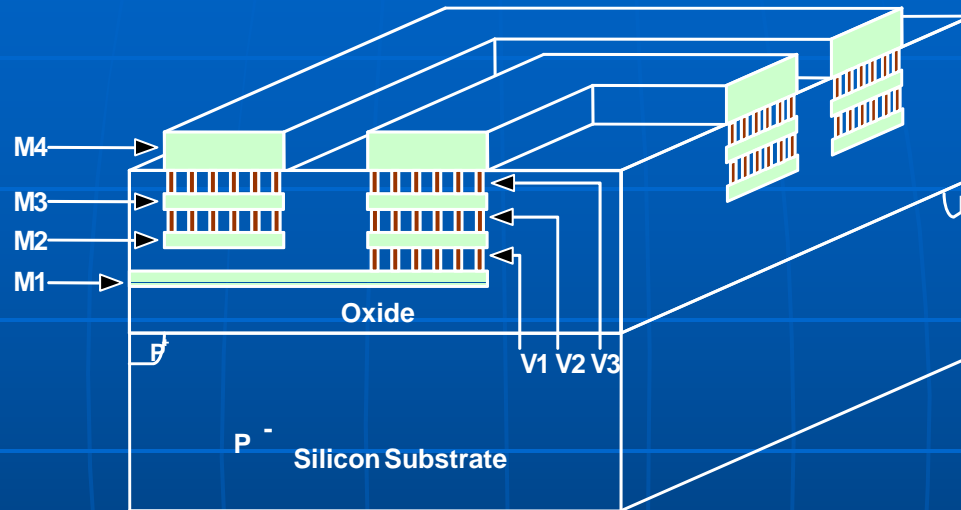

The series resistance is reduced with increasing number of vertical shunt among the metal layers. But this approach can increase  $C_{OX}$  and thus reduce the self-resonant frequency.



# Structure with Tapered Line Width



EM loss is most significant in center of spiral.  
The metal line width is tapered to reduce the magnetically induced losses in the inner turns.

# Structure with Stacked Metal Layers

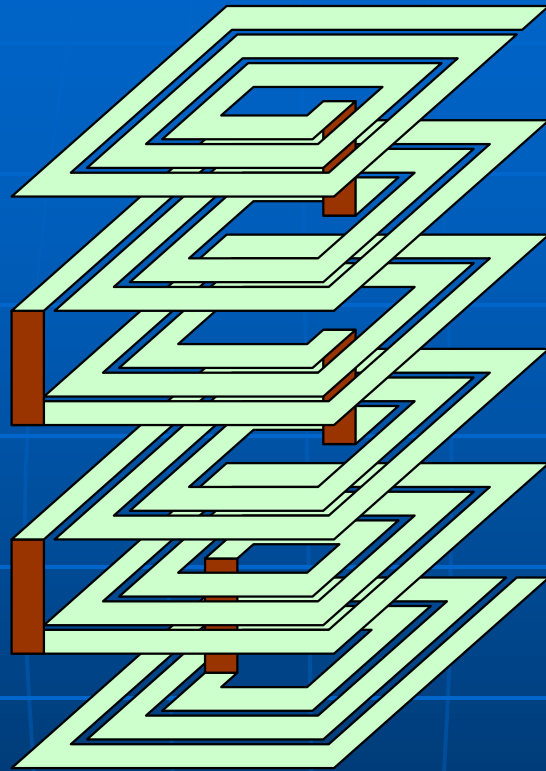

The stacked structure increases effective metal length, which increases the inductance without increasing the chip area

# Structure with Non-Symmetrical and Symmetrical Winding

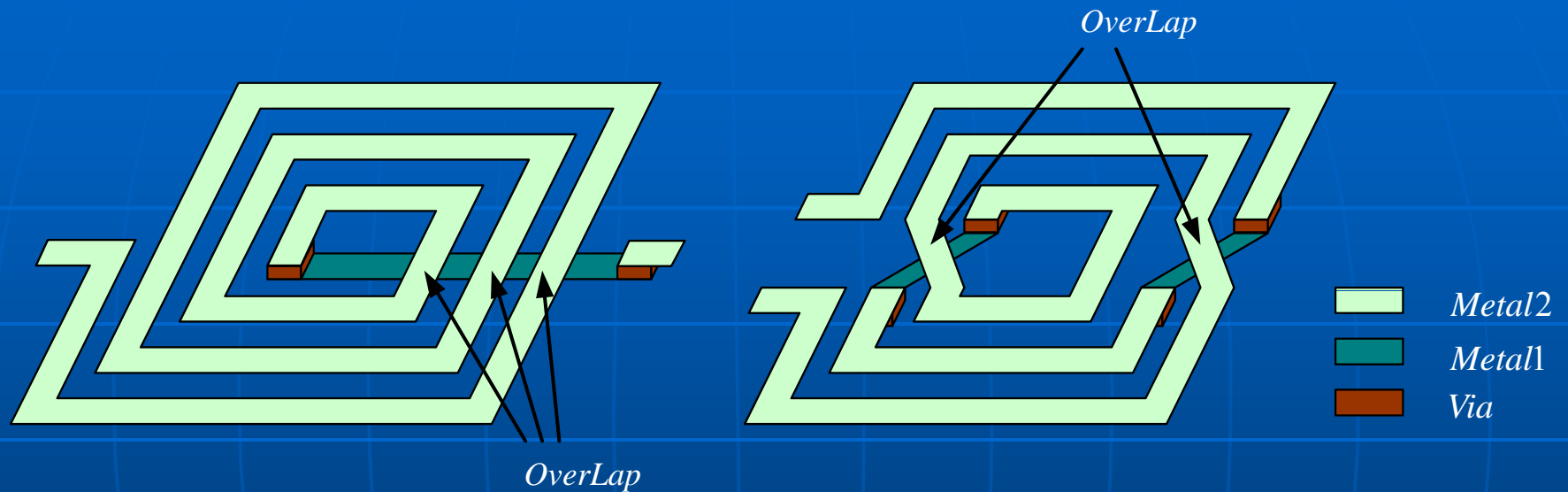

- The symmetrical winding improves the RF performance because
  - It has less overlap which reduces the Cs and
  - The geometric center is exactly the magnetic and electric center, which increases the mutual inductance

# Future Works

- Intrinsic Mesfet noises
- Phase noise in different topology
- Inductors in GaAs

# References

1. Hajimiri and T. Lee, "A general theory of phase noise in electrical oscillators," IEEE J. Solid-State Circuits, vol. 33, pp. 179–194, Feb. 1998.
2. Roberto Aparicio and Ali Hajimiri, "A Noise-Shifting Differential Colpitts VCO," IEEE, 2002.
3. Thomas H. Lee, Member, IEEE, and Ali Hajimiri, "Oscillator Phase Noise: A Tutorial", Member, IEEE, 2000.
4. Hajimiri and T. Lee, "Design issues in CMOS differential LC oscillators," IEEE J. Solid-State Circuits, vol. 34, pp. 716–724, May 1999.
5. Razavi, "A study of phase noise in CMOS oscillators," IEEE J. Solid-State Circuits, vol. 31, pp. 331–343, Mar. 1996.