

Session 1: Classical vs. Quantum Mechanics

Solid State Devices:

1

History of Chemistry

In fourth century B.C., ancient Greeks proposed that matter consisted of fundamental particles called **atoms**. Over the next two millennia, major advances in chemistry were achieved by **alchemists**. Their major goal was to convert certain elements into others by a process called **transmutation**.

In 400 B.C. the Greeks tried to understand matter (chemicals) and broke them down into **earth, wind, fire, and air**.

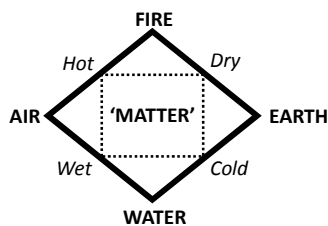

Relation of the four **ELEMENTS** and the four qualities

2

Rutherford's Atomic Model

Rutherford Scattering (1909):

The experimental results were not consistent with Thomson's atomic model.

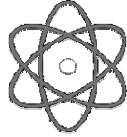

Rutherford proposed (1911) that an atom has a positively charged core (nucleus) surrounded by the negative electrons

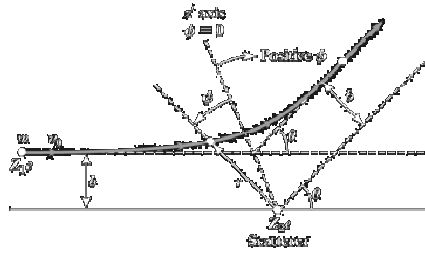

Ernest Rutherford (1871–1937)
New Zealand-born
father of nuclear physics
Nobel Prize in Chemistry (1908)



5

Failing of The Planetary Model

From classical E&M theory, an accelerated electric charge radiates energy (electromagnetic radiation) which means total energy must decrease. Radius r must decrease!!

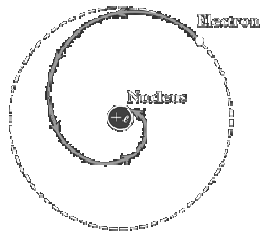

Electron crashes into the nucleus!?



Physics had reached a turning point in 1900 with Planck's hypothesis of the quantum behavior of radiation.

birth of Quantum mechanics

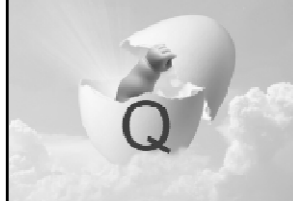

6

Am I Classical or Quantum?

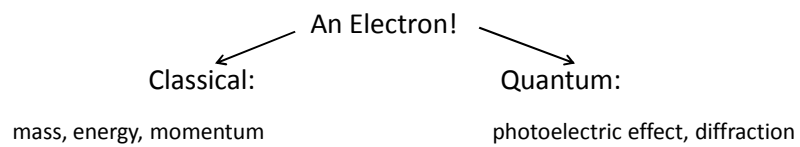

Wave-Particle Duality

deBroglie wavelength

$$\lambda = h / p$$

h = Planck's constant = 6.63×10^{-34} J·s (measured)

p = momentum

λ = wavelength

Is electron like a soccer ball or not?

Who knows!



7

Wave-Particle Duality

How do I look?



$m = 100 \text{ Kg}$



$m = 1 \text{ Kg}$

$v = 1 \text{ m/s}$

vs.

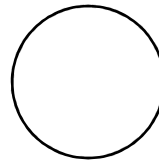

$m \approx 10^{-30} \text{ Kg}$

$v = 1 \text{ m/s}$

$\lambda = ?$

$\lambda = 6.6 \times 10^{-34} \text{ m}$

$\lambda = 6.6 \times 10^{-4} \text{ m}$

$E = 0.5 \text{ J}$

$E = 5 \times 10^{-31} \text{ J}$

$f = E/h = 7.5 \times 10^{32} / \text{s}$

$f = 757 / \text{s}$

8

Black Body Radiation

- Temperature is just average energy in each microscopic degree of motion ($(1/2)kT$, k = Boltzman's constant)
- Every object radiates light at its intrinsic frequencies of vibration etc.
- A Black Body absorbs all light incident, but must re-radiate light, whose intensity and spectrum depends only upon the temperature.

Classical Mechanics, and Classical EM gave prediction for black body radiation that:

1. Disagreed with experiments
2. Was logically inconsistent (Infinite total energy).

Planck (1900) found that a very simple formula could be used to calculate the quantum at a particular frequency of EMR

$$E = hf$$

E = energy of the radiation (J)
 h = Planck's Constant = 6.63×10^{-34} J·s
 f = frequency of the EMR (Hz)

Max Planck (1858 – 1947)
 Nobel Prize (1918)

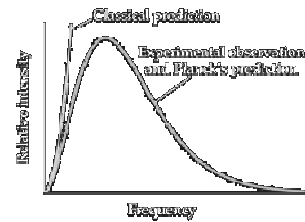
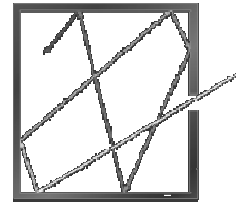

9

PhotoElectric Effect

- Light shining on a metal will liberate electrons, but the photon energy hf must be greater than a threshold energy (equal to binding energy of electron in metal.)
- The threshold effect is *independent of light intensity* (energy density of light).
- Na requires 2.5eV = Green

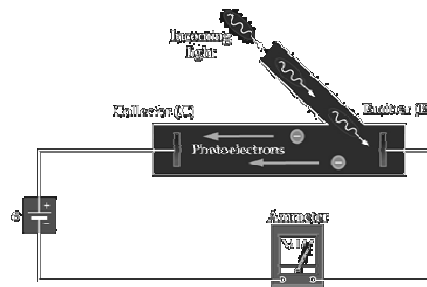

In **1905** an unknown physicist named **Albert Einstein** came up with an idea that built on what Planck had said.

The light consist of particles named photon.

Photon comes from the Greek word for light. Einstein originally called photons a "light quantum." The chemist Gilbert N. Lewis came up with the name photo.

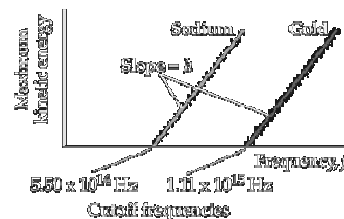

10

Fathers of Quantum Mechanics

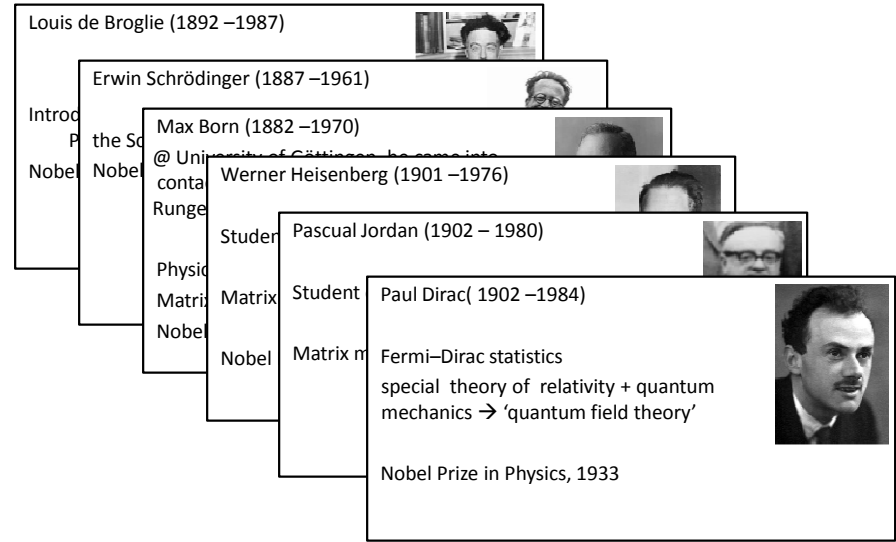

H₂ Emission & Absorption spectra.

Sun and stars are made of Hydrogen and Helium,

The galaxies are receding from us (redshift)

Balmer Series [Joseph Balmer, 1885]

$$\lambda = R \left(\frac{1}{2^2} - \frac{1}{n^2} \right), \quad n = 3, 4, 5, \dots$$

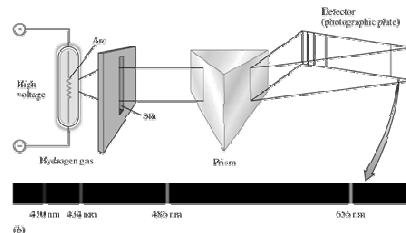
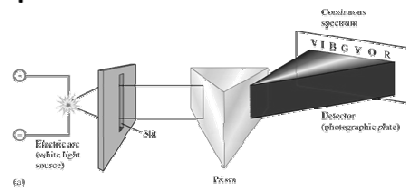
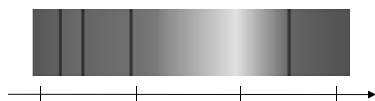

Photon Emission

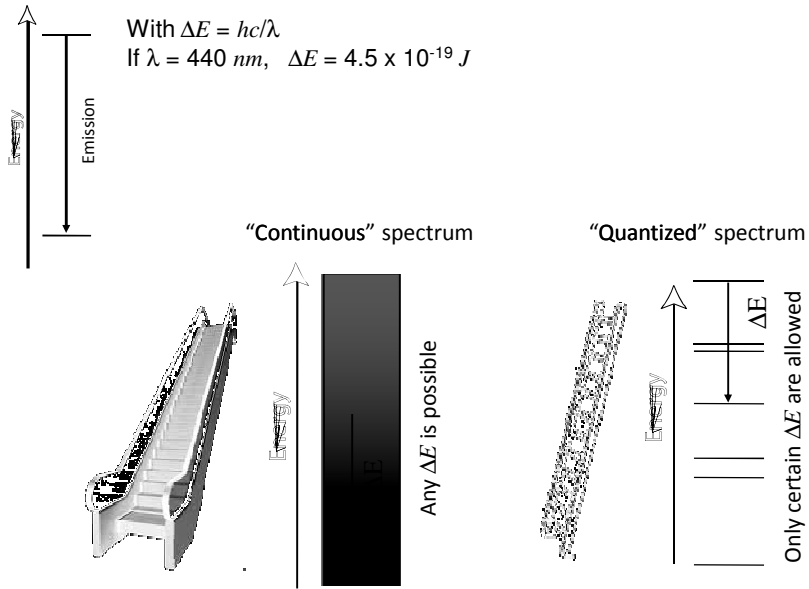

13

Bohr Atomic Model

Introduced by Niels Bohr (1885 –1962) in 1913, a Dane, proposed his model of the atom while working at Cambridge University in England

Atom: a small, positively charged nucleus surrounded by electrons that travel in circular orbits around the nucleus (similar to the solar system)

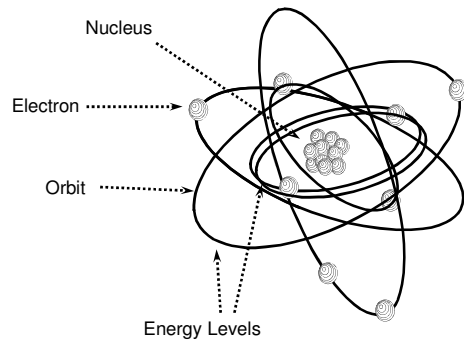

14

Bohr Atomic Model

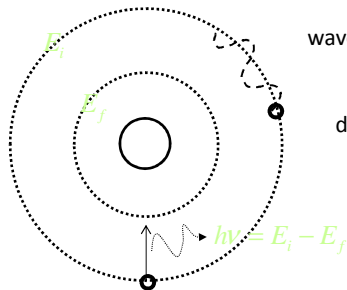

wave-particle duality $\lambda = h/p$

$$mvr = n\hbar$$

de Broglie standing wave

Louis de Broglie
his 1924 thesis(1892 –1987)
11 years later !



Bohr's postulate (1913):

- (1) An electron in an atom moves in a **circular orbit** about the nucleus under the influence of the **Coulomb** attraction between the electron and the nucleus, obeying the laws of classical mechanics.
- (2) An electron move in an orbit for which its orbital **angular momentum** is $L = n\hbar = nh / 2\pi$, $n = 1, 2, 3, \dots$, h Planck's constant
- (3) An electron with constant acceleration moving in an allowed orbit **does not radiate** electromagnetic energy. Thus, its total energy E remains constant.
- (4) Electromagnetic **radiation** is emitted if an electron, initially moving in an orbit of total energy E_i , discontinuously changes its motion so that it moves in an orbit of total energy E_f . The frequency of the emitted radiation is $\nu = (E_i - E_f) / h$.

15

Bohr's model

$$F = ma \rightarrow \frac{1}{4\pi\epsilon_0} \frac{Ze^2}{r^2} = m \frac{v^2}{r} \left. \begin{array}{l} \\ L = mvr = n\hbar \end{array} \right\} \rightarrow r_n = 4\pi\epsilon_0 \frac{n^2 \hbar^2}{mZe^2}$$

$$v_n = \frac{n\hbar}{mr_n} = \frac{1}{4\pi\epsilon_0} \frac{Ze^2}{n\hbar}$$

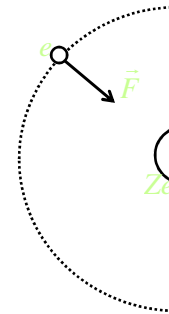

Potential energy: $V = -\int_r^\infty \frac{Ze^2}{4\pi\epsilon_0 r^2} dr = -\frac{Ze^2}{4\pi\epsilon_0 r}$

Kinetic energy: $K = \frac{1}{2}mv^2 = \frac{Ze^2}{4\pi\epsilon_0 2r}$

Total energy: $E = K + V = -\frac{Ze^2}{(4\pi\epsilon_0)^2 2r} = -K \Rightarrow$

$$E_n = -\frac{mZ^2 e^4}{(4\pi\epsilon_0)^2 2\hbar^2} \frac{1}{n^2} = -Z^2 \frac{13.6eV}{n^2}$$

16

Bohr Atomic Model

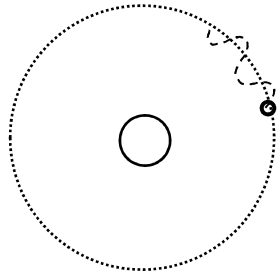

wave-particle duality $\lambda = \frac{h}{p}$

$$mvr = n\hbar$$

Energy Bands:

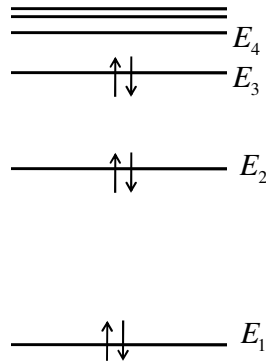

17

Bohr Atomic Model

$$\nu = \frac{E_i - E_f}{h}$$

$$= \left(\frac{1}{4\pi\epsilon_0}\right)^2 \frac{mZ^2e^4}{4\pi\hbar^3} \left(\frac{1}{n_f^2} - \frac{1}{n_i^2}\right)$$

$$\kappa = \frac{1}{\lambda} = \frac{\nu}{c}$$

$$= \left(\frac{1}{4\pi\epsilon_0}\right)^2 \frac{me^4Z^2}{4\pi\hbar^3c} \left(\frac{1}{n_f^2} - \frac{1}{n_i^2}\right)$$

$$= R_\infty Z^2 \left(\frac{1}{n_f^2} - \frac{1}{n_i^2}\right)$$

$$\text{for } R_\infty = \left(\frac{1}{4\pi\epsilon_0}\right)^2 \frac{me^4}{4\pi\hbar^3c} = R_H$$

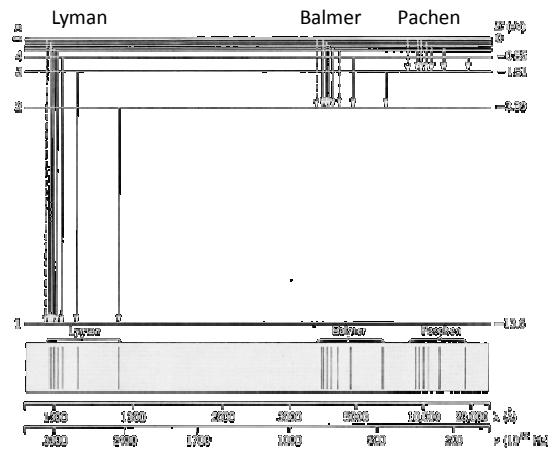

18

Quantum mechanics and real life

Why chalk is white, metals are shiny?

Colors ← Absorbing transitions ← transition energies ← QM

Blackbody radiation: Quantum statistics of radiation (is using to find temp. of stars)

For us as Elect. Engineers:

+ Solid state technology (Integrated circuits)

- tunneling through gate oxide

Information age is become available by QM!

QM arguably the greatest achievement of the twentieth century!

QM changed our view of the world/philosophy of life!

QM been attacked by many prominent scientist!

QM is "non-local"!

QM enables quantum computing!

QM is bizarre!

Tunneling

Heisenberg's uncertainty principle

Particle may exist in a superposition state

Measurement, collapse of the wavefunction

19

Uncertainty Principle

In quantum world, each particle is described by a **wave packet**. This wave behavior of the particle is reason behind uncertainty principle.

Precisely determined momentum



A sine wave of wavelength λ , implies that the momentum p is precisely known but the wavefunction is spread over all space.

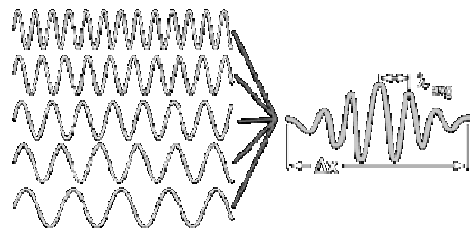

Adding several waves of different wavelength together will produce an interference pattern which localizes the wave. But the process spreads the momentum and makes it more uncertain.

Inherently:

$$\Delta p \Delta x \geq h/(2\pi)$$

20

Diffraction & Uncertainty Principle

$\sin\theta = \lambda/W$
 Uncertainty
 $\Delta y \approx W/2$
 $\Delta p_y \approx p \sin\theta = (h/\lambda) (\lambda/W)$
 $\Delta p_y \Delta y = h/2$
 Heisenberg:
 $\Delta p_y \Delta y \geq h/(2\pi)$
 Uncertainty principle is a consequence of wave nature of matter.

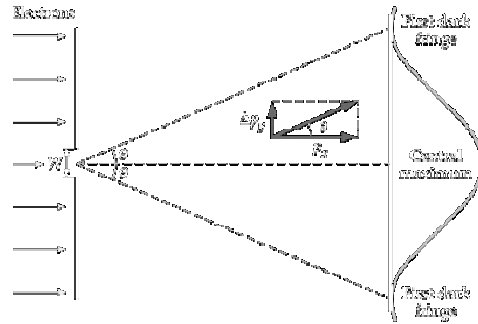

21

Interference – double slit

Plain wave: $\psi \propto e^{i\mathbf{k}\cdot\mathbf{r}}$

assume $L \gg d$

Wave on the screen:

$$\psi_{screen} \propto e^{ik\sqrt{(x-d/2)^2+L^2}} + e^{ik\sqrt{(x+d/2)^2+L^2}}$$

$$\psi_{screen} \propto e^{i\phi} \cos\left(\frac{kd x}{2L}\right)$$

where $\phi = k \left[L + \frac{x^2}{2L} + \frac{d^2}{8L} \right]$

$$|\psi_{screen}(x)|^2 \propto \cos^2\left(\frac{\pi d x}{\lambda L}\right) = \frac{1}{2} [1 + \cos\left(\frac{2\pi d x}{\lambda L}\right)]$$

Hence a beam of monoenergetic electrons produces a sinusoidal interference pattern, or "fringes", on the screen, with the fringes separated by a distance $\lambda_s = \lambda L/d$

Young's double slits

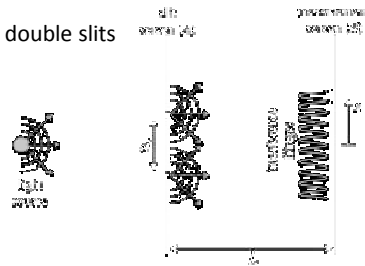

electron double slits

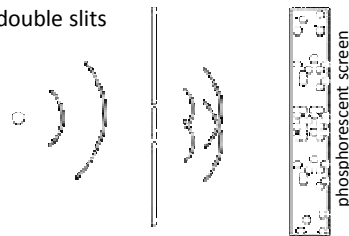

22

Double slit and Quantum Mechanics

some bizarre consequences:

By blocking 1 slit → interference fringes disappear

By uncovering 1 slit → parts the screen that were bright now become dark

extremely low electron currents (never 2 electrons at given time)

→ same interference pattern

Diffractive effects are strong when the wavelength is comparable to the size of an object.

$$\lambda_{e^-} \sim 0.1nm$$

- Spacing between the atoms are on the order of Å.
- Electron microscope!

23

Schrödinger Equation

Electron can behave like plane wave with $\lambda = h/p$ wave equation $\Psi = Ae^{i2\pi x/\lambda}$

Simplest choice: Helmholtz wave equation for monochromatic wave

$$\nabla^2 \Psi = -k^2 \Psi \quad \text{where} \quad k = 2\pi/\lambda = p/\hbar$$

$$-\hbar^2 \nabla^2 \Psi = p^2 \Psi$$

$$-\frac{\hbar^2}{2m_0} \nabla^2 \Psi = \frac{p^2}{2m_0} \Psi \rightarrow \frac{p^2}{2m_0} = \text{K.E.} = \text{Total energy}(E) - \text{Potential energy}(V)$$

$$-\frac{\hbar^2}{2m_0} \nabla^2 \Psi = (E - V(r)) \Psi$$

$$\left(-\frac{\hbar^2}{2m_0} + V(r) \right) \nabla^2 \Psi = E \Psi$$

time-independent Schrodinger equation

Note: we have not "derived" Schrödinger's equation. Schrödinger's equation has to be postulated, just like Newton's laws of motion were originally postulated. The only justification for making such a postulate is that it works!

24

Schrödinger Equation

$$E = \sqrt{m_0^2 c^4 + p^2 c^2} = m_0 c^2 \left[1 + \frac{p^2 c^2}{2m_0^2 c^4} + \dots \right]$$

$$E - m_0 c^2 = V + \frac{p^2}{2m_0} = V + \frac{\hbar^2 k^2}{2m_0}$$

$$h\nu = \hbar\omega = V + \frac{\hbar^2 k^2}{2m_0}$$

$$\Psi(x, t) = A e^{-i(\omega t - kx)}$$

$$\frac{d\Psi}{dt} = -i\omega\Psi \quad \text{and} \quad \frac{d^2\Psi}{dx^2} = -k^2\Psi$$

$$\boxed{-\frac{\hbar^2}{2m_0} \frac{d^2\Psi}{dx^2} + V(x)\Psi = i\hbar \frac{d\Psi}{dt}}$$

time-dependent Schrodinger equation

25

Schrödinger Equation

$$-\frac{\hbar^2}{2m_0} \frac{d^2\Psi}{dx^2} + V(x)\Psi = i\hbar \frac{d\Psi}{dt}$$

$$\Psi(x, t) = \psi(x)\phi(t) = \psi(x)e^{-iEt/\hbar}$$

$$-\frac{\hbar^2}{2m_0} \frac{d^2\psi}{dx^2} e^{-iEt/\hbar} + V(x)\psi(x)e^{-iEt/\hbar} = i\hbar \frac{-iE}{\hbar} \psi(x)e^{-iEt/\hbar}$$

$$-\frac{\hbar^2}{2m_0} \frac{d^2\psi}{dx^2} + V(x)\psi = E\psi$$

26

Probability Density

Physical interpretation of the wavefunction

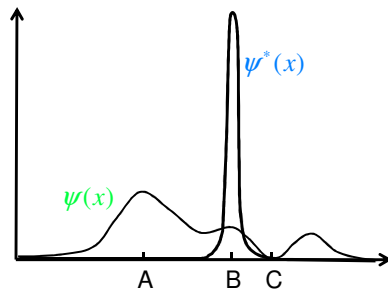

$P(r) = \text{probability of finding a particle at } r \propto |\psi(r)|^2$

$$\int |\psi(r)|^2 d^3r = 1$$

Most likely at A, never can be found at C!
If we find it at B, what does it mean?

Measurement will change the wave function! The value of ψ is not measurable. However, all measurable quantities of a particle can be derived from ψ .

It is meaningless to talk about the position of the particle, as a wave function describes it, but we can find the **expected value** for the position, $\langle x \rangle$.

$$\langle x(t) \rangle = \int x |\psi(x, t)|^2 dx$$

$$\langle \xi(t) \rangle = \int \psi^*(x, t) \xi \psi(x, t) dx$$

27

Operator

$\langle x(t) \rangle = \int x |\psi(x, t)|^2 dx$ Show that:

$$\frac{d\langle x \rangle}{dt} = -\frac{i\hbar}{m} \int \psi^* \frac{\partial \psi}{\partial x} dx$$

Momentum operator:

$$p = mv = m \frac{d\langle x \rangle}{dt} = -i\hbar \int \psi^* \frac{\partial \psi}{\partial x} dx = \int \psi^* \left(-i\hbar \frac{\partial}{\partial x}\right) \psi dx$$

general operator:

$$\langle Q \rangle = \int_{-\infty}^{+\infty} (\Psi^* \hat{Q} \Psi) dx dy dz$$

28

Postulates of Q Mechanics

3D wave-function: $\Psi(x, y, z; t)$ $\Psi(\vec{r}, t)$ $\psi(\vec{r})$

1D wave-function: $\Psi(x, t)$

window of QM to the real world $\Psi(x, t)\Psi^*(x, t)$

Classical:

Dynamical variables:
position, momentum, energy

Quantum:

Operators

We have seen operators before

$$\frac{d}{dx} \Psi(x, t)$$

↑ ↑
operator operand

29

Postulate 1:

The state of a system is described by a wave function of the coordinates and the time

$\Psi(\vec{r}, t)$, (which is often complex-valued) the complete wavefunction depends on coordinates r and time t .

$\Psi^*(\vec{r}, t) \Psi(\vec{r}, t) d\tau$ is the probability that the system is in the volume element $d\tau$ at time t .

Thus Ψ and $\partial\Psi/\partial x, y, z$ must be:

(1) Single-valued; (2) Continuous; (3) Quadratically integrable.

Example: The wavefunction of the plane monochromatic light

$$\psi = Ae^{i2\pi(\frac{x}{\lambda} - vt)}$$

wave-particle duality

$$E = h\nu, p = h/\lambda$$

$$\psi = Ae^{i\frac{2\pi}{\lambda}(xp_x - Et)}$$

30

Postulate 2:

The motion of a nonrelativistic particle is governed by the Schrödinger equation

$$\hat{H}\Psi = -\frac{\hbar^2}{2m_0} \frac{d^2\Psi}{dx^2} + V(x)\Psi = i\hbar \frac{d\Psi}{dt}$$

time-dependent Schrodinger equation

$$\Psi(x,t) = \psi(x)\phi(t) = \psi(x)e^{-iEt/\hbar}$$

$$-\frac{\hbar^2}{2m_0} \frac{d^2\psi}{dx^2} + V(x)\psi = E\psi$$

time-independent Schrodinger equation

If $\psi_1, \psi_2, \dots, \psi_n$ are the possible states of a microscopic system, then the **linear combination** of these states is also a possible state of the system

$$\Psi = \sum_i c_i \psi_i$$

In classical systems: we often use linear equations as a first approximation to nonlinear behavior

In quantum mechanics: The linearity of the equations with respect to the quantum mechanical amplitude is **not an approximation** of any kind. this linearity allows the full use of linear algebra for the mathematics of quantum mechanics.

31

Postulate 3:

For every classical observable there is a corresponding **linear hermitian** quantum mechanical operator.

Classical operator	Mathematical operator
Position, x	$\hat{x} = x$
Momentum(x), p_x	$\hat{p}_x = -i\hbar \frac{\partial}{\partial x}$
$f(p_x)$	$f(\hat{p}_x)$
Kinetic Energy, $K=p^2/2m$	$\hat{K} = \hat{p}^2/2m$
Potential Energy, V	$\hat{V} = V$
Energy, $E=K+V$ (Schrödinger eq.)	$\hat{H} = i\hbar \frac{\partial}{\partial t}$

$$\langle Q \rangle = \int_{-\infty}^{+\infty} (\Psi^* \hat{Q} \Psi) dx dy dz$$

32

Pauli's Exclusion Principle

Every atomic or molecular orbital can only contain a maximum of two electrons with opposite spins.

33

Simple Problems

Free electron (metals)



Particle in a box (quantum well, optoelectronic)

Ideal (infinite) well

Finite well



Potential wall (transmission, reflection)

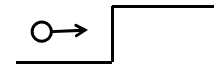

Tunneling (Tunneling diode, STM)



Kronig-Penning problem (Solid state, Bandgap)



Harmonic oscillator (acoustic vibration \rightarrow phonon,
Emag waves \rightarrow photon)

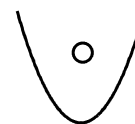

34

Free Electron

$$-\frac{\hbar^2}{2m_0} \frac{d^2\psi}{dx^2} + V(x)\psi = E\psi \quad \text{time-independent Schrodinger equation}$$

Free electron $V(x) = 0$, with energy E

$$\frac{d^2\psi}{dx^2} = -\frac{2m_0E}{\hbar^2}\psi = -k^2\psi$$

$$\psi = A_+e^{-ikx} + A_-e^{+ikx}$$

$$\Psi(x, t) = A_+e^{-i(kx-\omega t)} + A_-e^{+i(kx-\omega t)}$$

$$k = \frac{\sqrt{2m_0E}}{\hbar}$$

$$E = \frac{\hbar^2 k^2}{2m_0}$$

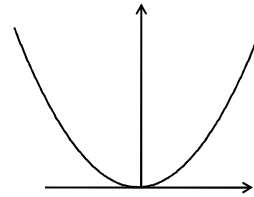

35

Effective mass

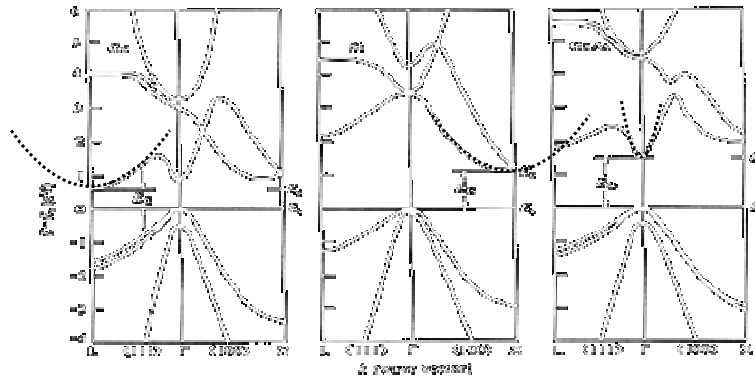

$$E = \frac{\hbar^2 k^2}{2m_0} \rightarrow m^* = \frac{\hbar^2}{d^2 E / dk^2}$$

36

1D Quantum Well (Box)

Consider a particle with mass m under potential as:

Outside the box:

$$V = \infty \rightarrow \psi = 0 \quad [?]$$

Inside box:

$$\frac{d^2\psi}{dx^2} + \frac{2mE}{\hbar^2}\psi = 0$$

$\sin kx, \cos kx$ as $k = \sqrt{2mE}/\hbar$

continuity of ψ at 0 and L:

$$\psi(0) = \psi(L) = 0 \rightarrow \psi = A \sin kx ; k = \frac{n\pi}{L}, n = 1, 2, 3, \dots$$

n is the quantum number
↓

$$\frac{n\pi}{L} = \frac{\sqrt{2mE_n}}{\hbar} \rightarrow E_n = \frac{n^2\pi^2\hbar^2}{2mL^2}$$

normalization:

$$\int_{-\infty}^{+\infty} \psi^* \psi dx = \int_0^L A^2 (\sin \frac{n\pi x}{L})^2 dx = 1 \rightarrow A = \sqrt{\frac{2}{L}}$$

$$\psi_n = \sqrt{\frac{2}{L}} \sin\left(\frac{n\pi}{L}x\right)$$

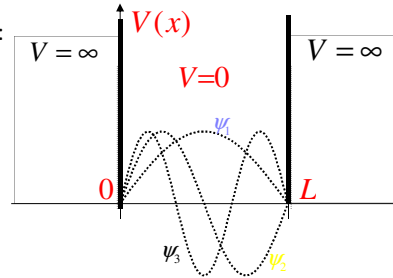

37

1D Quantum Well (Box)

$$E_n = \frac{n^2\pi^2\hbar^2}{2mL^2}$$

$$\psi_n = \sqrt{\frac{2}{L}} \sin\left(\frac{n\pi}{L}x\right)$$

$L \nearrow \infty \rightarrow$ free electron

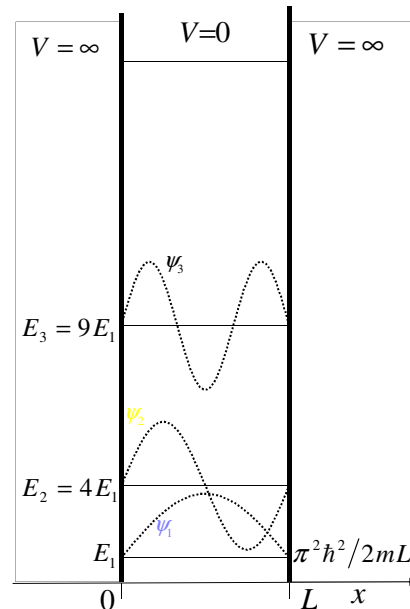

38

Eigenvalues & Eigenfunctions

Solutions:

with a specific set of allowed values of a parameter (here energy), **eigenvalues** E_n (eigenenergies) and with a particular function solution associated with each such value, **eigenfunctions** ψ_n

It is possible to have more than one eigenfunction with a given eigenvalue, a phenomenon known as **degeneracy**.

even function
odd function

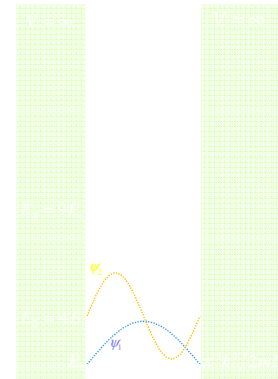

Note:

It is quite possible for solutions of quantum mechanical problems not to have either odd or even behavior, e.g., if the potential was not itself symmetric.

When the potential is symmetric, odd and even behavior is very common.

Definite parity is useful since it makes certain integrals vanish exactly.

39

Quantum behavior

Only **discrete** values of that energy possible, with specific wave functions associated with each such value of energy. This is the first truly "quantum" behavior we have seen with "quantum" steps in energy between the different allowed states.

Differences from the classical case:

- 1 - only a **discrete** set of possible values for the energy
- 2 - a minimum possible energy for the particle, above the energy of the classical "bottom" of the box,

$$E_1 = \pi^2 \hbar^2 / 2mL^2$$

sometimes called a "**zero point**" energy (**ground state**).

- 3 - the particle is **not uniformly** distributed over the box, (almost never found very near to the walls of the box) the probability obeys a standing wave pattern.

In the lowest state ($n=1$), it is most likely to be found near the center of the box. In higher states, there are points inside the box, where the particle will never be found. Note that each successively higher energy state has one more "zero" in the eigenfunction. this is very common behavior in quantum mechanics.

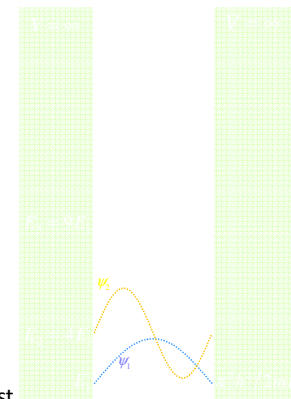

$$L \sim 0.5nm \quad (\text{atom})!$$

$$E_1 = 1.5eV$$

$$E_2 - E_1 = 4.5eV$$

40

Sets of Eigenfunctions

completeness of sets of eigenfunctions.

Familiar case: Fourier series

$$f(t) = \sum_{n=1}^{\infty} a_n \sin\left(\frac{n\pi t}{T}\right)$$

Similarly for every $f(x)$, $0 < x < L$:

$$f(x) = \sum_{n=1}^{\infty} a_n \sin\left(\frac{n\pi x}{L}\right) = \sum_{n=1}^{\infty} b_n \psi_n(x)$$

$$\text{as } \psi_n = \sqrt{\frac{2}{L}} \sin\left(\frac{n\pi}{L}x\right) \text{ hence } b_n = \sqrt{\frac{L}{2}} a_n$$

we can express any function between positions $x = 0$ and $x = L$ as an expansion in the eigenfunctions of this quantum mechanical problem.

Note that there are many other sets of functions that are also complete.

A set of functions such as the ψ_n that can be used to represent a function such as the $f(x)$ is referred to as a “basis set of functions” or simply, a “basis”.

The set of coefficients (amplitudes) b_n is then the “representation” of $f(x)$ in the basis ψ_n .

Because of the completeness of the set of basis functions ψ_n , this representation is just as good a one as the set of the amplitudes at every point x between 0 and L .

41

Sets of Eigenfunctions

In addition to being “complete,” the set of functions $\psi_n(x)$ are “orthogonal”.

Definition: Two functions $g(x)$ and $h(x)$ are orthogonal if

$$\int_0^L g^*(x)h(x)dx = 0$$

Definition: Kronecker delta $\delta_{mn} = \begin{cases} 0, & m \neq n \\ 1, & m = n \end{cases}$

$$\int_0^L \psi_n^*(x)\psi_m(x)dx = \delta_{mn}$$

A set of functions that is both normalized and mutually orthogonal, is said to be “orthonormal”.

Orthonormal sets are very convenient mathematically, so most basis sets are chosen to be orthonormal. Note that orthogonality of different eigenfunctions is very common in quantum mechanics, and is not restricted to this specific example where the eigenfunctions are sine waves.

$$f(x) = \sum_n c_n \psi_n(x) \rightarrow c_m = \int \psi_n^*(x) f(x) dx$$

42

1D Finite Well

We first need to find the values of the energy for which there are solutions to the Schrödinger equation, then deduce the corresponding wavefunctions. Boundary conditions are given by continuity of the wavefunction and its first derivative.

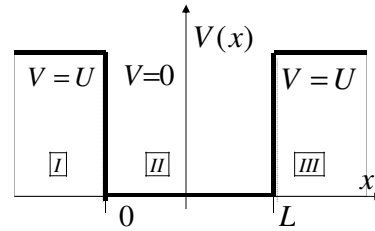

assume $E < U$

$$U(x) = \begin{cases} 0 & 0 < x < L \\ U & \text{Otherwise} \end{cases}$$

Region II

$$\frac{d^2\psi}{dx^2} = -\frac{2mE}{\hbar^2}\psi = -k^2\psi, \quad k = \frac{\sqrt{2mE}}{\hbar}$$

$$\psi_{II}(x) = F \sin kx + G \cos kx$$

Region I and III

$$\frac{d^2\psi}{dx^2} = \frac{2m(U-E)}{\hbar^2}\psi = \alpha^2\psi, \quad \alpha = \frac{\sqrt{2m(U-E)}}{\hbar}$$

$$\Rightarrow \psi = Ae^{\alpha x} + Be^{-\alpha x}, \quad x < 0 \text{ and } x > L$$

$$(\text{Finite } \psi) \Rightarrow \begin{cases} \psi_I = Ae^{\alpha x}, & x < 0 \\ \psi_{III} = Be^{-\alpha x}, & x > L \end{cases}$$

43

1D Finite Well

$$\begin{cases} \psi_I = Ae^{\alpha x}, & x < 0 \\ \psi_{II} = F \sin kx + G \cos kx, & 0 < x < L \\ \psi_{III} = Be^{-\alpha x}, & x > L \end{cases}$$

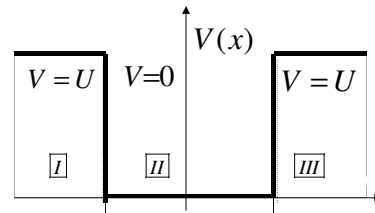

$$\begin{cases} \psi_I = \psi_{II} @ x=0 \\ \frac{d\psi_I}{dx} = \frac{d\psi_{II}}{dx} @ x=0 \\ \psi_{II} = \psi_{III} @ x=L \\ \frac{d\psi_{II}}{dx} = \frac{d\psi_{III}}{dx} @ x=L \\ \int_{-\infty}^{\infty} |\psi(x)|^2 dx = 1 \end{cases} \Rightarrow \begin{cases} A \\ B \\ F \\ G \\ \alpha \Rightarrow E \end{cases}$$

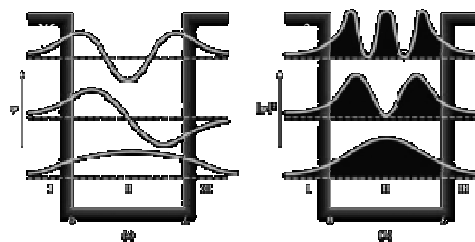

for $E < U$: (1) Quantization of energies. (2) Particle almost bounded In the well.

for $E > U$: all energies are possible. (plane wave)

44

Finite vs. Infinite Well

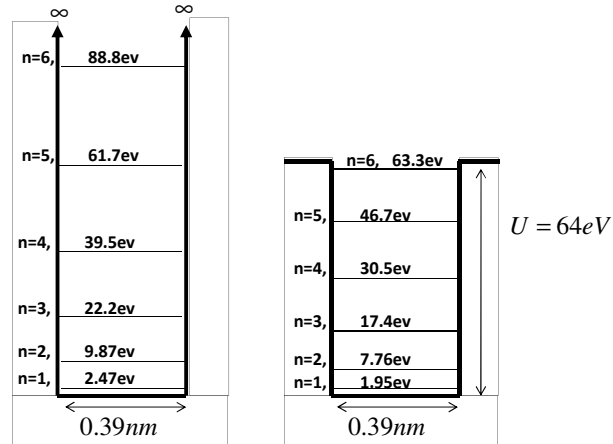

Potential Wall

$$\text{For } x < 0: -\frac{\hbar^2}{2m_0} \frac{d^2\psi_I}{dx^2} = E\psi_I$$

$$\frac{d^2\psi_I}{dx^2} + k^2\psi_I = 0 \quad \text{where } k = \sqrt{2mE}/\hbar$$

$$\text{For } x > 0: -\frac{\hbar^2}{2m_0} \frac{d^2\psi_{II}}{dx^2} + V_0\psi_{II} = E\psi_{II}$$

$$\frac{d^2\psi_{II}}{dx^2} - \alpha^2\psi_{II} = 0 \quad \text{where } \alpha = \sqrt{2m(E - V_0)}/\hbar$$

$$\psi_I = Ae^{ikx} + Be^{-ikx} \quad (x < 0)$$

$$\psi_{II} = Ce^{\alpha x} + De^{-\alpha x} \quad (x > 0)$$

$$\text{B.C.} \begin{cases} \psi_I(0) = \psi_{II}(0) \\ \left. \frac{\partial \psi_I}{\partial x} \right|_{x=0} = \left. \frac{\partial \psi_{II}}{\partial x} \right|_{x=0} \end{cases} \rightarrow \begin{cases} A + B = 0 \\ ik(A - B) = -\alpha D \end{cases}$$

$$\begin{cases} \Psi_I(x, t) = Ae^{i(kx - Et/\hbar)} + Be^{i(kx + Et/\hbar)} \\ \Psi_{II}(x, t) = De^{-\alpha x - iEt/\hbar} \end{cases}$$

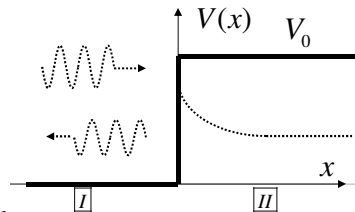

$$\frac{C}{A} = 2 \frac{E - i\sqrt{(V_0 - E)E}}{V_0}$$

$$\frac{B}{A} = \frac{2E - V_0 - 2i\sqrt{(V_0 - E)E}}{V_0}$$

$$\left| \frac{B}{A} \right|^2 = 1 \quad \text{Classically meaningless!!}$$

$$E = 1eV, V_0 = 2eV$$

$$\rightarrow 1/\alpha = 0.2nm$$

$$\text{penetration depth} = 0.1nm$$

Potential Wall

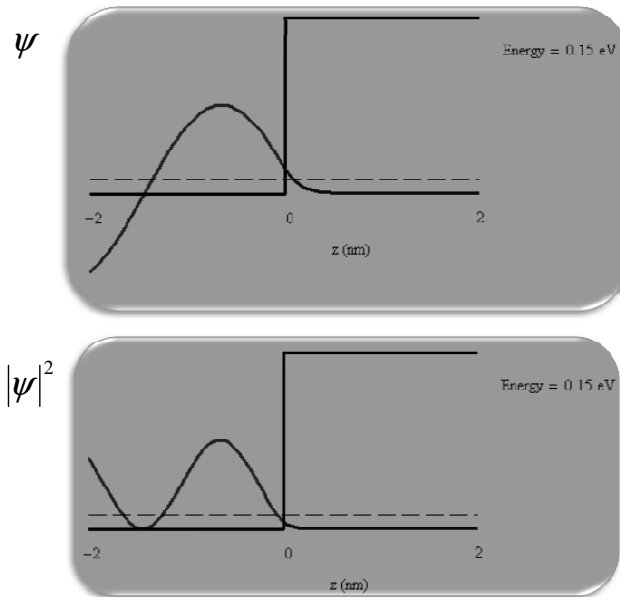

47

Tunnling

$$-\frac{\hbar^2}{2m} \frac{d^2\psi}{dx^2} + U\psi = E\psi$$

$$\begin{cases} \psi_I = e^{ikx} + re^{-ikx}, & x < 0 \\ \psi_{II} = Ae^{\alpha x} + Be^{-\alpha x}, & 0 < x < L \\ \psi_{III} = te^{ikx}, & x > L \end{cases}$$

$$k = \sqrt{2mE}/\hbar, \quad \alpha = \sqrt{2m(U-E)}/\hbar$$

$$\begin{cases} \psi_I = \psi_{II} @ x=0 \\ \frac{d\psi_I}{dx} = \frac{d\psi_{II}}{dx} @ x=0 \\ \psi_{II} = \psi_{III} @ x=L \\ \frac{d\psi_{II}}{dx} = \frac{d\psi_{III}}{dx} @ x=L \end{cases} \Rightarrow \begin{cases} A \\ B \\ t \Rightarrow T = |t|^2 \\ r \Rightarrow R = |r|^2 \end{cases}$$

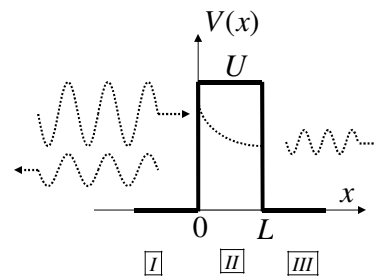

- **Transmission coefficient (T):** The probability that the particle penetrates the barrier.
- **Reflection coefficient (R):** The probability that the particle is reflected by the barrier.
- $T + R = 1$

48

Tunneling

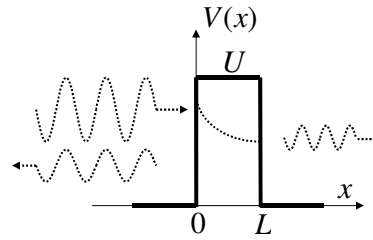
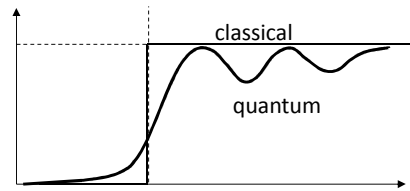

$$T = \left[1 + \frac{U^2}{4E(E-U)} \sin^2(\alpha L) \right]^{-1}$$

$$\alpha = \sqrt{2m(U-E)}/\hbar$$

$$\text{For } U = E, \quad T = \left[1 + \frac{E m L^2}{2 \hbar^2} \right]^{-1}$$

$$\text{For } U \gg E, \quad T \approx \exp \left[-\frac{2L}{\hbar} \sqrt{2m(U-E)} \right]$$

49

Applications of Tunneling

Alpha decay:

In order for the alpha particle to escape from the nucleus, it must penetrate a barrier whose energy is several times greater than the energy of the nucleus-alpha particle system.

Nuclear fusion:

Protons can tunnel through the barrier caused by their mutual electrostatic repulsion.

Scanning tunneling microscope:

- The empty space between the tip and the sample surface forms the "barrier".
- The STM allows highly detailed images of surfaces with resolutions comparable to the size of a single atom: 0.2 nm lateral, 0.001nm vertical.

50

Why Harmonic Oscillator?

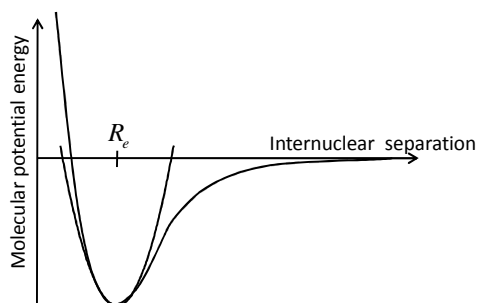

51

Harmonic Oscillator

A particle subject to a restoring force: $F = -kx = -m\omega^2 x$

The potential energy: $U(x) = \frac{1}{2}kx^2 = \frac{1}{2}m\omega^2 x^2$

The Schrödinger equation: $-\frac{\hbar^2}{2m} \frac{d^2\psi}{dx^2} + \frac{1}{2}m\omega^2 x^2 \psi = E\psi$

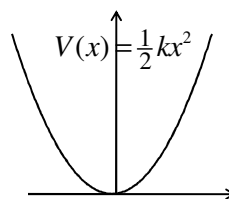

Let us *guess*: $\psi(x) = B \exp(-Cx^2) \Rightarrow C = \frac{m\omega}{2\hbar}, E = \frac{1}{2}\hbar\omega$

This is actually the ground state.

The actual solution:
$$\begin{cases} \psi_n(x) = \sqrt{\frac{\sqrt{m\omega/\hbar}}{\sqrt{\pi} 2^n n!}} \exp\left(-\frac{m\omega}{2\hbar} x^2\right) H_n\left(\sqrt{\frac{m\omega}{\hbar}} x\right) \\ E_n = \left(n + \frac{1}{2}\right) \hbar\omega, \quad n = 0, 1, 2, \dots \end{cases}$$

Hermite polynomial

52

Harmonic Oscillator

$$E_n = \left(n + \frac{1}{2}\right) \hbar \omega, \quad n = 0, 1, 2, \dots$$

$$\text{Ground state} \quad E_0 = \frac{1}{2} \hbar \omega$$

$$\Delta E = \hbar \omega$$

- The blue curves represent probability densities for the first three states.
- The orange curves represent the *classical* probability densities corresponding to the same energies.
- As n increases, the agreement between the classical and the quantum-mechanical results improves.

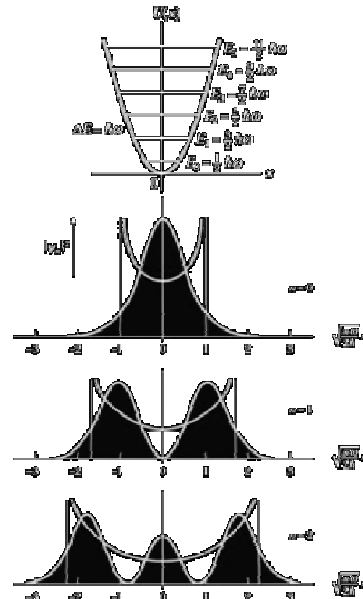
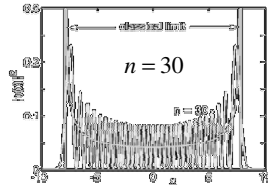

53

Linearly varying potential

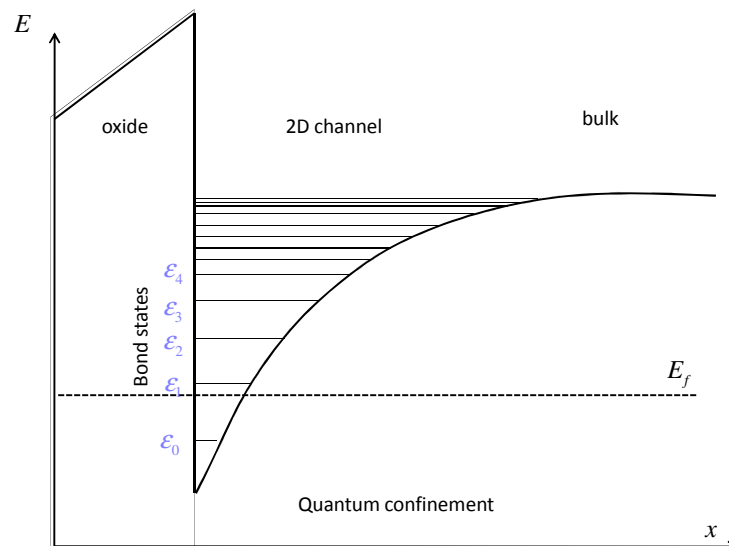

54